



TACHPRO

**ENGINE DISPLAY AND MONITORING SYSTEM
MODELS: TPA300, TPA320**



FIRE RESEARCH CORPORATION

www.fireresearch.com

26 Southern Blvd., Nesconset, NY11767

TEL (631) 724-8888 FAX (631) 360-9727 **TOLL FREE 1-800-645-0074**

CONTENTS

Table of Contents

CONTENTS	2
INTRODUCTION	3
Overview	3
Features	3
Specifications	4
GENERAL DESCRIPTION	5
Components	5
Operation	5
INSTALLATION	6
DIAGNOSTICS	8
WIRING	9
FLYBACK DIODE INFORMATION	11

List of Tables

Table 1. Fault Codes	8
----------------------------	---

List of Figures

Figure 1. Display Module Mounting Dimensions	7
Figure 2. Display Module Cable	7
Figure 3. Wiring	9
Figure 4. Flyback Diode	11

INTRODUCTION

Overview

The **TACHPRO** is an instrument panel in one compact easy to read module. This instrument panel will take the clutter out of the pump panel and yet provide the pump operator with useful engine information. It is also a device that is capable of both visual and audible warning.

The **TACHPRO** has a 4 digit LED display for engine RPM, and 3 LED bar graphs to display the engine oil pressure, engine coolant temperature, and battery voltage. The program supports the accumulation of elapsed pump hours in a non-volatile, transferable memory module. Pump hours are displayed at the push of a button.

The **TACHPRO** utilizes the data broadcasted on the J1587 public data link (from the engine ECM) to display the engine information. The battery voltage is monitored directly through the battery instead of displaying the ECM battery voltage. (Sometimes the engine ECM is powered by a separate battery).

Features

Engine RPM Display

Oil Pressure Display with Low Pressure Warnings

Engine Temperature Display with High Temperature Warnings

Battery Voltage Display with Low and Over Voltage Warnings

Pump Hour Memory

Specifications

Power:	12 VDC
Current:	0.6 Amps
Dimensions:	4.88" X 4.88" X 3.125"
Buzzer:	12 VDC @ 95 dB
Engine Oil Pressure:	0 -90 psi, Warning: < 8 psi
Coolant Temperature:	150 -240 deg F, Warning: > 220° F
Battery Warnings:	
Low Voltage:	11.7 V (Engine Stopped)
	11.8 V (Engine Running)
High Voltage:	15.4 V
Pump Hours:	0-999.9 Hours (Wrap around after 999.9 hours.)

GENERAL DESCRIPTION

Components

The **TACHPRO** is supplied with the necessary sending units and extension cables for installations. The following components are supplied with the standard **TACHPRO**:

TACHPRO Display Module

Buzzer

Extension Cables

Oil Pressure Sending Unit (TPA320 only)

For the electronic engines, the **TACHPRO** receives the information on the engine RPM, oil pressure, and coolant temperature over the J1587 data link from the engine ECM. In this case no additional sensors are needed.

Operation

Read the Pump Hours

The **TachPro** has a pump hour built in it to track the pump operating hours for pump maintenance. The timer is displayed in 0.1 hour increment up to 999.9 hour. (The timer will wrap around and start at 0.0 hour once it passes 999.9.) To read the timer, press and hold the **SILENCE** button for 6 seconds. The RPM display will show the accumulated hours. Release the **SILENCE** button to display the engine RPM again.

Audible and Visual Warnings

The **TachPro** will provide an audible and visual warning when:

Engine oil pressure is lower than 8 PSI

Engine temperature is above 220° F (visual) and 230° F (audible)

Battery voltage is below 11.8 VDC (with the engine running)

Battery voltage is above 15.6 VDC

Silence the Audible Warning

The audible warning can be silenced by pressing the **SILENCE** button. This will not cancel the visual alarm. The visual alarm will reset itself once the conditions return to normal.

INSTALLATION

The **TACHPRO** is simple to install! It is small and compact. The overall dimension taken by the **TACHPRO** on the pump panel is less than 5 inches square. This will free up valuable panel space and eliminate the need for multiple meters.

Install Display Module

The display module requires a cutout hole of 3 3/4" on the pump panel. Four 10-32 mounting screws are needed to secure the display module on the pump panel. Refer to Figure 1 for dimensional information and Figure 3 for wiring.

Install Buzzer

A buzzer is supplied with the **TACHPRO**. Install the buzzer close to the **TACHPRO** so that it is easier to associate the audible warning with the visual warning on the **TACHPRO**. A cutout hole of 1-1/8" (1.125") is required on the pump panel.

Install Oil Pressure Sensor (TPA320 only)

The oil pressure sender supplied has a range of 0-100 psi. The thread size for this sending unit is 1/8" NPTF. Install the sending unit directly into the engine block pressure port. **DO NOT USE ANY PIPE SEALANT OR TEFLON TAPE BECAUSE THIS WILL GENERATE AN INSULATION LAYER BETWEEN THE SENSOR AND THE VEHICLE BODY.** Use a hex wrench and tighten the sender at the pipe thread. **DO NOT USE PIPE WRENCH ON THE SENDER BODY.** Tighten the sender into the pressure port with a minimum of 5 turns. Check for no leaks immediately upon start-up.

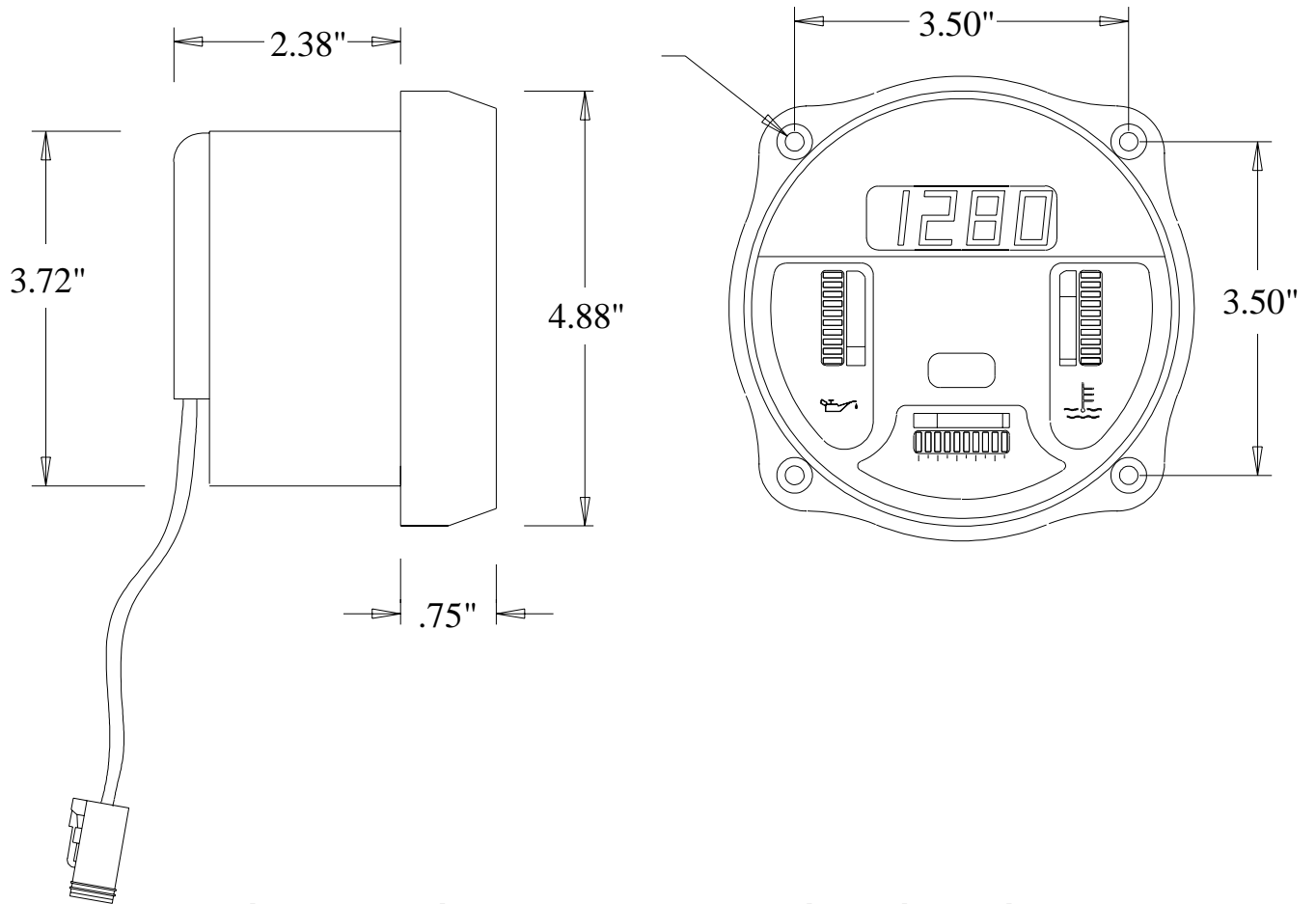
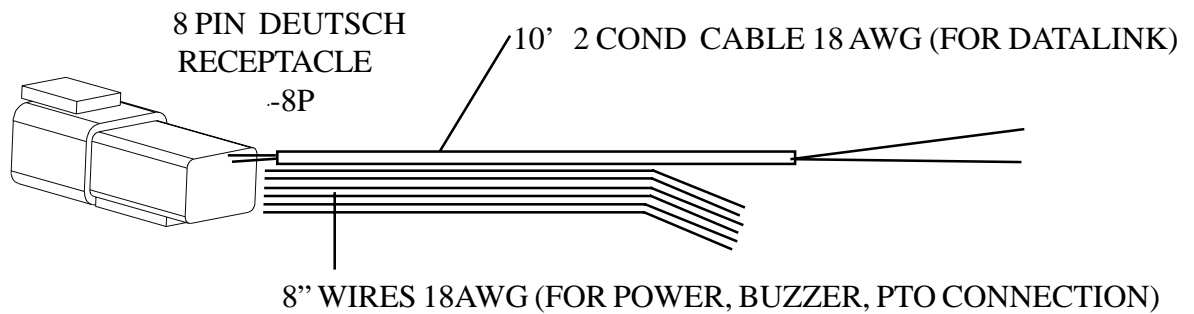

Figure 1. Display Module Mounting Dimensions

Extension cable:



Mememory module:



Figure 2. Display Module Cable

DIAGNOSTICS

Table 1. Fault Codes

Fault Codes	Descriptions
E1	No data is detected on the J1587 data bus
E3	No RPM data is detected on the data bus
E9	No oil pressure data is detected on the data bus
E8	Bad or missing memmory module
E10	No coolant temperature data is available on the data bus

WIRING

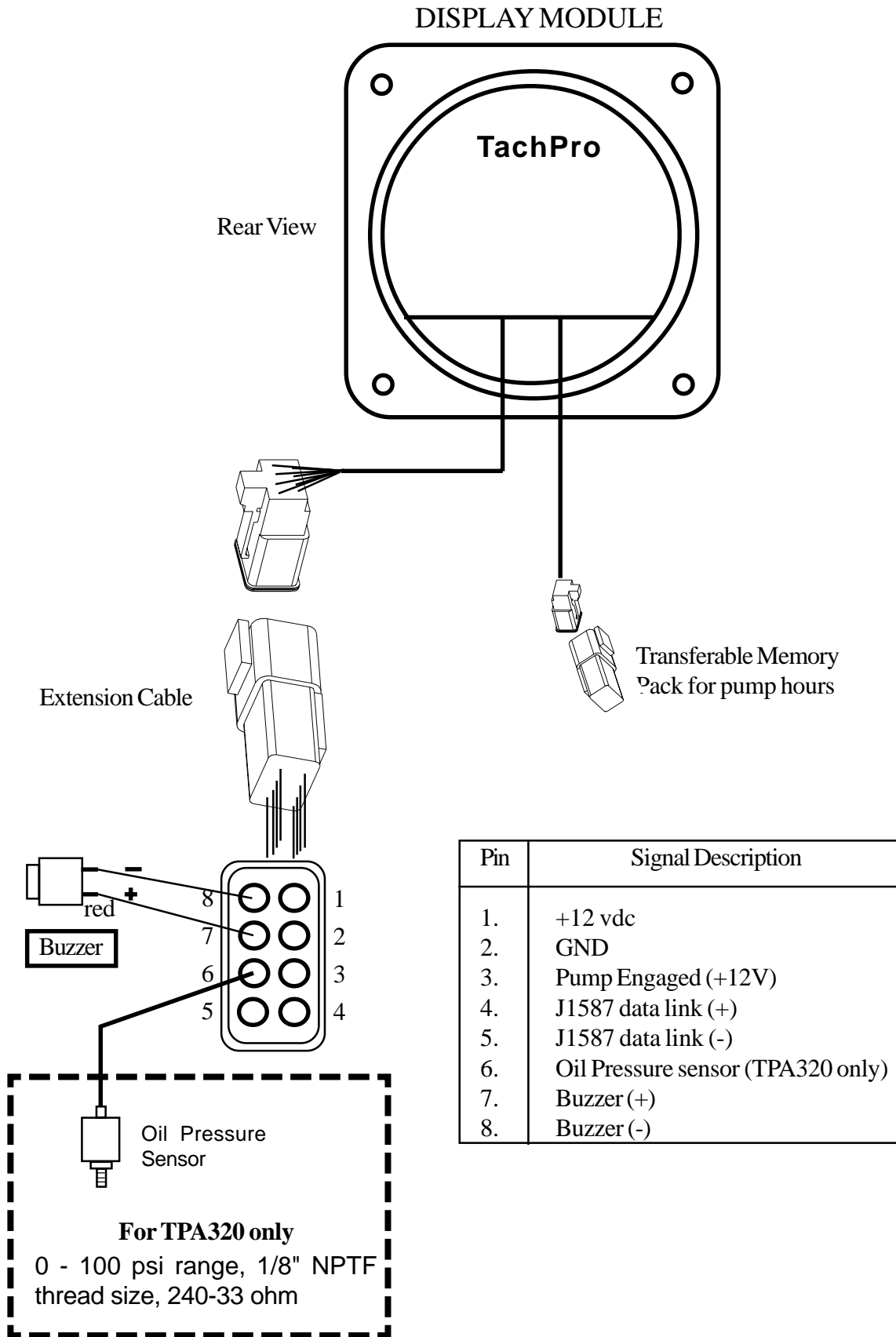

Figure 3. Wiring

This page intentionally left blank.

FLYBACK DIODE INFORMATION

It is good engineering practice to include a flyback diode when switching an inductive load (solenoid coil, relay coil, electric motor winding, etc.). It is recommended that a flyback diode be installed on inductive devices that share a common power source/ground with a FRC governor.

Typical circuit showing a flyback diode installed across an inductive load.
(Relay Coil, Solenoid, etc.)

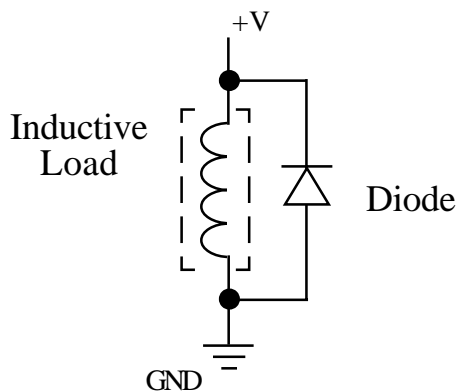

Diagram showing a flyback diode connected on a typical pump primer motor solenoid.

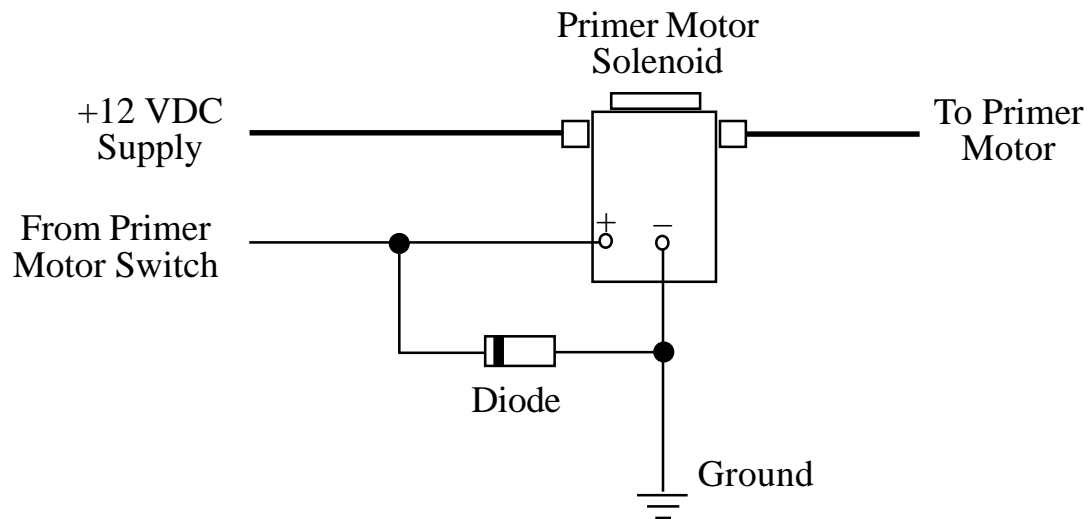

Figure 4. Flyback Diode