



---

---

# PROS

## PRESSURE GOVERNOR

### MODEL: PRA200



**FIRE RESEARCH CORPORATION**

<http://www.fireresearch.com>

26 Southern Blvd., Nesconset, NY11767

TEL (631) 724-8888 FAX (631) 360-9727 **TOLL FREE 1-800-645-0074**

# CONTENTS Table of Contents

CONTENTS .....	2
List of Tables .....	3
List of Figures .....	3
INTRODUCTION .....	4
Overview .....	4
Features .....	4
Specifications .....	5
GENERAL DESCRIPTION .....	7
Components .....	7
Controls and Indicators .....	8
INSTALLATION .....	10
Install Control Module .....	10
Install Pressure Sensor .....	11
Install Throttle Servomotor (Non-Electronic Engine Only) .....	12
Install Optional High Idle .....	14
OPERATION .....	15
Pressure Mode Operation .....	16
RPM Mode Operation .....	17
Change Preset Setting (Pressure or RPM) .....	17
System Options .....	18
CALIBRATION .....	19
RPM Calibration (PRO-S 3, 6, and 8) .....	19
High Idle Option Calibration .....	20
3rd Gear Lock-up RPM Calibration (Ford 6.0L) .....	20
DIAGNOSTICS .....	21
WIRING .....	22
Power .....	22
High Idle .....	23
Pressure Sensor .....	24
Common OME Diagnostic Connectors .....	25
Cummins PRA201 Cables .....	26
Detroit Diesel (Series 50 and 60) PRA202 Cables .....	30
Non-Electronic Engine PRA203 Cables .....	32
Navistar PRA204 Cables .....	34
Caterpillar PRA205 Cables .....	36
Ford PRA206 Cables .....	40
Mack PRA207 Cables .....	44
Scania PRA208 Cables .....	46
Mercedes PRA210 Cables .....	50
FLYBACK DIODE INFORMATION .....	52

## List of Tables

Table 1. Pressure Sensor Output Voltage .....	5
Table 2. Diagnostic Codes .....	21

## List of Figures

Figure 1. Controls and Indicators .....	9
Figure 2. Control Module Mounting Dimensions .....	10
Figure 3. Pressure Sensor .....	11
Figure 4. Fuel Control Arm .....	12
Figure 5. Throttle Servo Motor .....	13
Figure 6. PRO-S Supply Power Wiring .....	22
Figure 7. Optional High Idle Schematic .....	23
Figure 8. Pressure Sensor Wiring .....	24
Figure 9. Common OEM Diagnostic Connectors .....	25
Figure 10. Cummins PRA201 Wiring .....	26
Figure 11. Detroit Diesel (Series 50 and 60) PRA202 Wiring .....	30
Figure 12. Non-Electronic PRA203 Wiring .....	32
Figure 13. Navistar PRA204 Wiring .....	34
Figure 14. Caterpillar PRA205 Wiring .....	36
Figure 15. Ford PRA206 Wiring .....	40
Figure 16. Mack PRA207 Wiring .....	44
Figure 17. Scania PRA208 Wiring .....	46
Figure 18. Mercedes PRA210 Wiring .....	50
Figure 19. Flyback Diode .....	52

# INTRODUCTION

## Overview

The Fire Research **PRO-S** pressure governor uses state of the art programmable microprocessor technology. It will maintain a steady pump discharge pressure by controlling the engine speed or maintain a selected engine RPM. The **PRO-S** operates in one of two modes, pressure or RPM.

In pressure mode the **PRO-S** maintains a constant pump discharge pressure. The discharge pressure is monitored and compared to the selected pressure setting, the engine RPM is varied to keep the discharge pressure at the selected setting.

In RPM mode the **PRO-S** maintains a constant engine RPM. The pump discharge pressure is monitored, it can vary but will be limited to an increase of 30 PSI. If the discharge pressure increases 30 PSI, the pressure governor will automatically lower the engine RPM to reduce the discharge pressure.

All controls and indicators are located on the front of the control module.

## Features

Power Up in Pressure Mode

Automatic Regulation of Pump Discharge Pressure

Manual Control of Pressure or Engine RPM Settings

Field Programmable Presets

Diagnostic Capabilities

No Pressure or RPM Variation When Changing Modes

Limits Increase of Pressure When in RPM Mode

Recognition of No Water Condition With Automatic Response

Interlock Signal Recognition

Return to Engine Idle With the Push of a Button

High Idle Kit (Optional)

24 VDC (Optional)

KPa (Optional)

## Specifications

The **PRO-S** is available in various models. Each model is programmed to interface with specific engines. All models provide the same functions, push button controls, and digital readout for the management of pump discharge pressure.

### Display Module

Supply Power:	12 VDC (24 VDC Optional)
Supply Current:	1.0 Amps (3.0 Amps for PRA203)
Dimensions:	4 1/4" Wide by 4 1/4" High

### Pressure Sensor

Model Number:	XE-PRO31PT2-S
Pressure Range:	0 - 300 PSI
Proof Pressure:	800 PSI
Excitation Voltage:	5 VDC
Output Voltage:	0.5 - 4.75 VDC (See Table 1)

**Table 1. Pressure Sensor Output Voltage**

PRESSURE	VOLTAGE
0	0.5
100	1.917
150	2.625
200	3.33
250	4.04
300	4.75

This page intentionally left blank.

## GENERAL DESCRIPTION

The **PRO-S** pressure governors are compatible with the following engines:

PRA201	Cummins ISB, ISC, ISM, and ISL		
PRA202	Detroit Diesel (Series 50 and 60)		
PRA203	Non-Electronic diesel and gasoline		
PRA204	Navistar		
PRA205	Caterpillar	PRA206	Ford
PRA207	Mack	PRA208	Scania
PRA210	Mercedes		

## Components

The **PRO-S** pressure governors consists of the following components:

Control Module

Pressure Sensor

Throttle Servomotor (Non-electronic engines only.)

High Idle Kit (Optional)

Cables

### Control Module

The pressure governor control module is waterproof and has dimensions of 4.25 inches high by 4.25 inches wide by 3.5 inches deep (4.5 inches deep on non-electronic and 24 VDC units). All controls and indicators are located on the front of the control module. (Refer to Controls and Indicators.)

### Pressure Sensor

The pressure sensor is mounted on the pump discharge manifold. It provides an input signal to the control module that is proportional to the discharge pressure.

### Throttle Servomotor (Non-Electronic Engines Only)

The throttle servomotor is installed on engines that do not have electronic engine control systems. It provides the mechanical connection between the control module and the engine throttle. The travel of the linear actuator arm is 1.85 inches.

### High Idle Kit (Optional)

The High Idle Kit provides the components to install this option including a DPDT switch, 2500 ohm potentiometer, an indicator light, two diodes, and a cable.

---

## Controls and Indicators

All controls and indicators are located on the front of the control module. It contains the push button electronic controls, LED indicators, and a digital display. (Refer to Figure 1.)

### **PRESET Button**

Press green PRESET button to change/select a pre-programmed value for pressure or RPM setting. This button is used when programming pressure or RPM preset values.

### **IDLE Button**

The red IDLE button immediately sets the engine to idle RPM. This button can be used in an emergency or for a normal shut down after operations.

### **SETTING Display**

The SETTING display shows a diagnostic error code, IdLE for engine idle, the pressure setting or the RPM setting. The LED digital display has daylight bright digits at least 0.56 inch high.

### **INCREASE Button**

During operations the yellow INCREASE button raises pressure or RPM setting. This button is also used in the programming of the pressure or RPM preset values.

### **DECREASE Button**

During operations the yellow DECREASE button lowers pressure or RPM setting. This button is also used in the programming of the pressure or RPM preset values.

### **RPM Button**

The green RPM button selects the RPM mode of operation.

### **RPM LED**

The red RPM LED is on to indicate operation in the RPM mode.

### **PRESSURE Button**

The green PRESSURE button selects the pressure mode of operation.

### **PRESSURE LED**

The amber PRESSURE LED is on to indicate operation in the pressure mode.

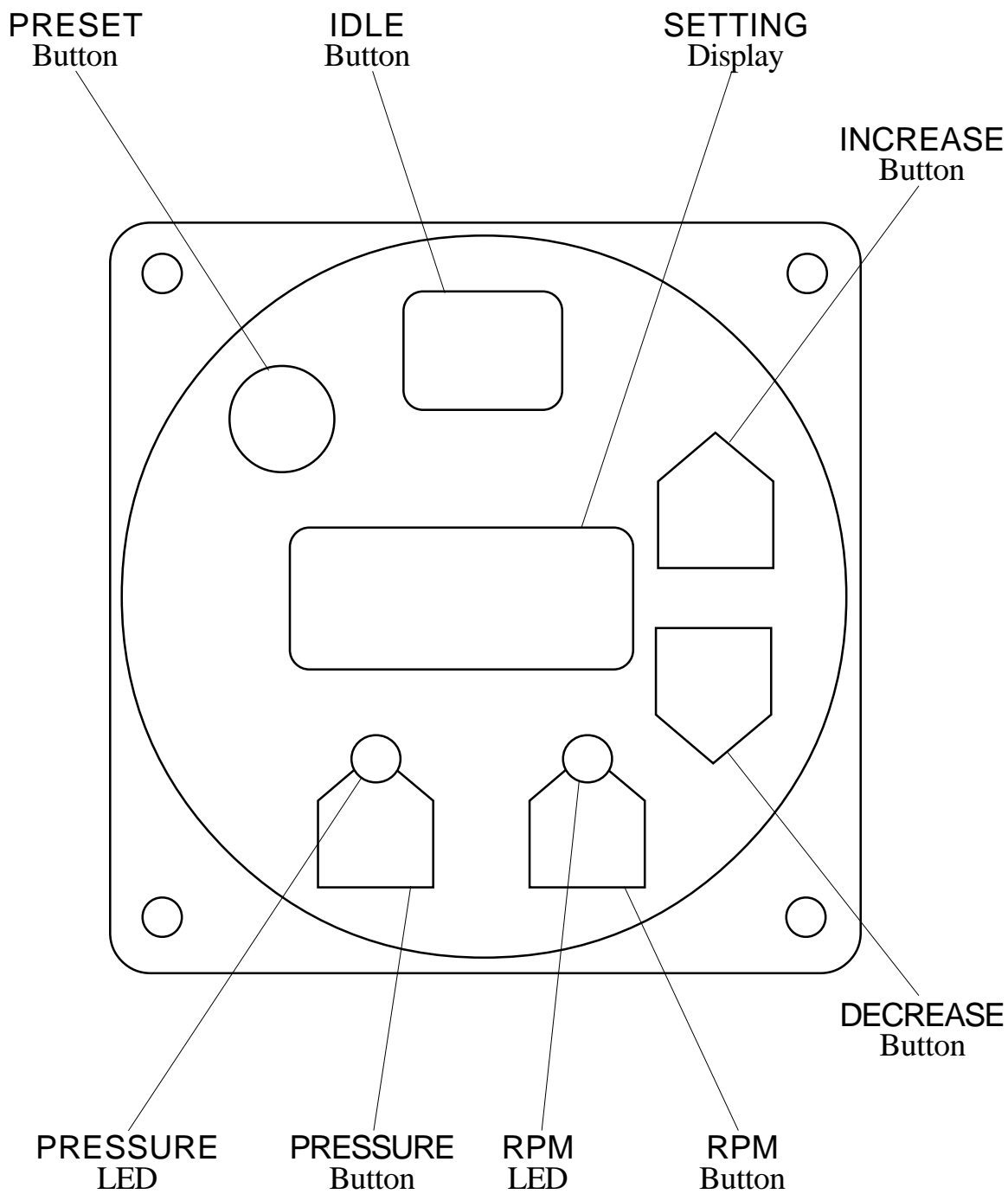

**Figure 1. Controls and Indicators**

# INSTALLATION

## Install Control Module

**Note:** The control module can be mounted anywhere on the pump panel. It should be mounted close to the engine warning indicators.

1. Measure and mark mounting location for control module panel cutout and mounting screw holes. Make sure there is clearance behind the panel for the module and cables before cutting holes. Refer to Figure 2 for layout and dimensions.
2. Cut out a 3.75-inch diameter hole and drill four holes for mounting screws.
3. Place control module in position and secure with four screws (10-32 mounting hardware is recommended).

**Note:** If the optional remote high idle kit is not being installed, ensure that the high idle cap (and pin B to pin C jumper wire) is installed on the end of the control module high idle cable.

4. Connect cables at rear of the control module. (Refer to Wiring Section.)

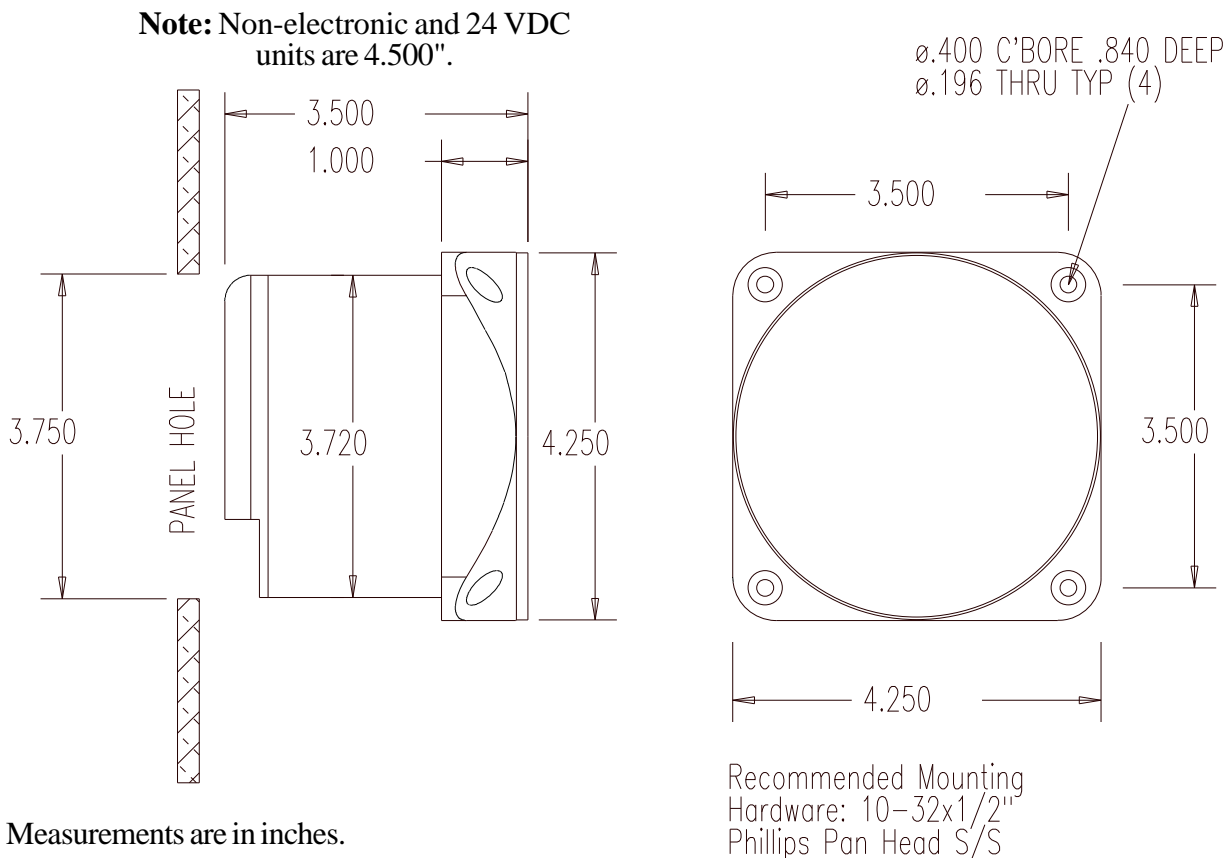

**Figure 2. Control Module Mounting Dimensions**

## Install Pressure Sensor

The discharge pressure sensor is mounted on the discharge manifold of the pump. A T-fitting can be used to share the master pressure gauge outlet on the discharge manifold. If there is a check valve in the discharge side of the pump, mount the sensor before the check valve.

**Note:** Install the pressure sensor upright so water in the end of the pressure sensor is able to drain back into the pipe.

1. Screw the sensor into a 1/4-18 NPT hole.

**Caution:** Do not use the main body that houses the electronics to tighten the pressure sensor. Damage to the sensor may occur.

2. Tighten the sensor with a 3/4-inch wrench on the lower hex fitting.
3. Connect the pressure sensor cable from the control module to the pressure sensor. (Refer to Wiring Section.)

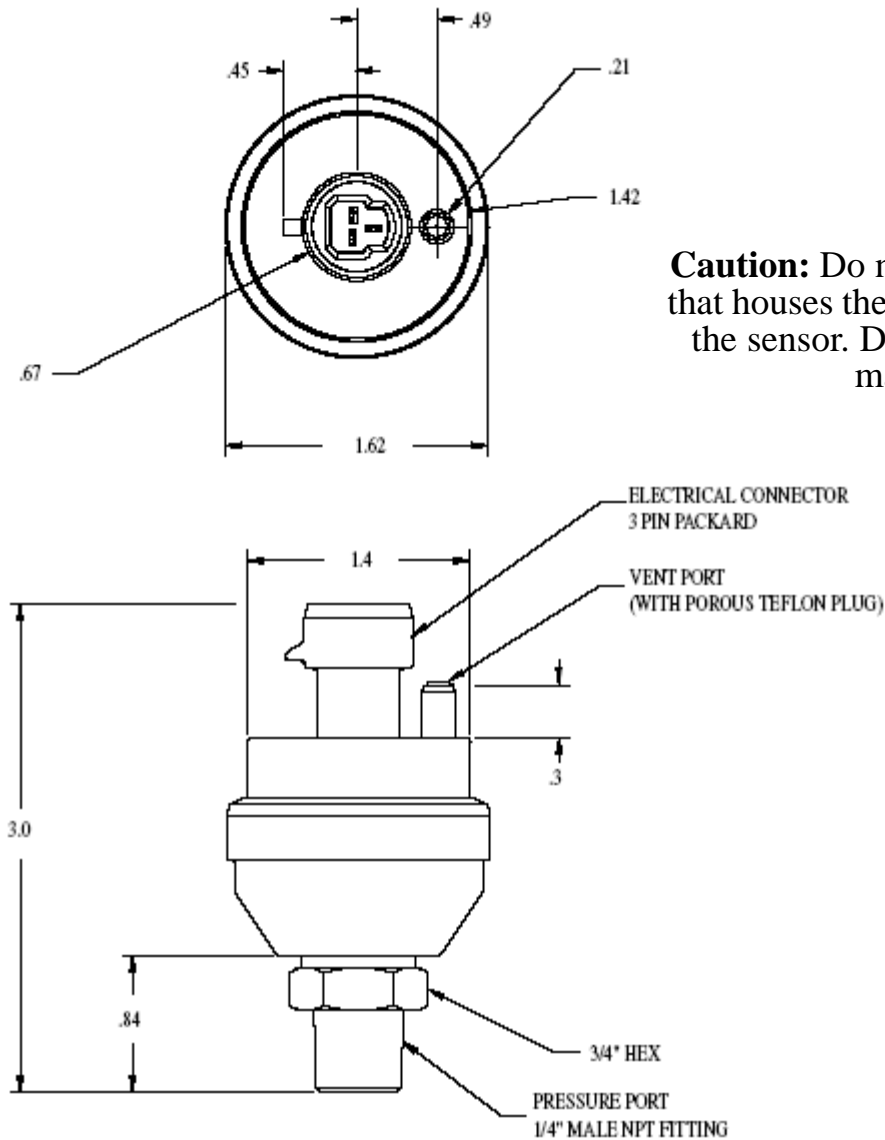

**Caution:** Do not use the main body that houses the electronics to tighten the sensor. Damage to the sensor may occur.

**Figure 3. Pressure Sensor**

## Install Throttle Servomotor (Non-Electronic Engine Only)

The throttle servomotor (FRC part number XE-PR34M) is used for engines that do not have an electronic engine control system.

The throttle servomotor has a universal mounting flange with six mounting holes. It should be mounted in a location where vibration and high temperatures will be minimized.

**Note:** The throttle cable (or linkage rod) varies for each installation and is not supplied with the throttle servomotor.

### Minimize Engine Oscillation

It is important to note that in order to minimize engine oscillations the stroke at the point the cable attaches to the fuel control arm should be 2 inches.

The length of the stroke at the point the cable attaches to the fuel control arm has a direct effect on the sensitivity of the system. The shorter the stroke, the more sensitive the system. Most engine oscillations occur because this stroke distance is too short. To increase the stroke distance, increase the length of the fuel control arm.

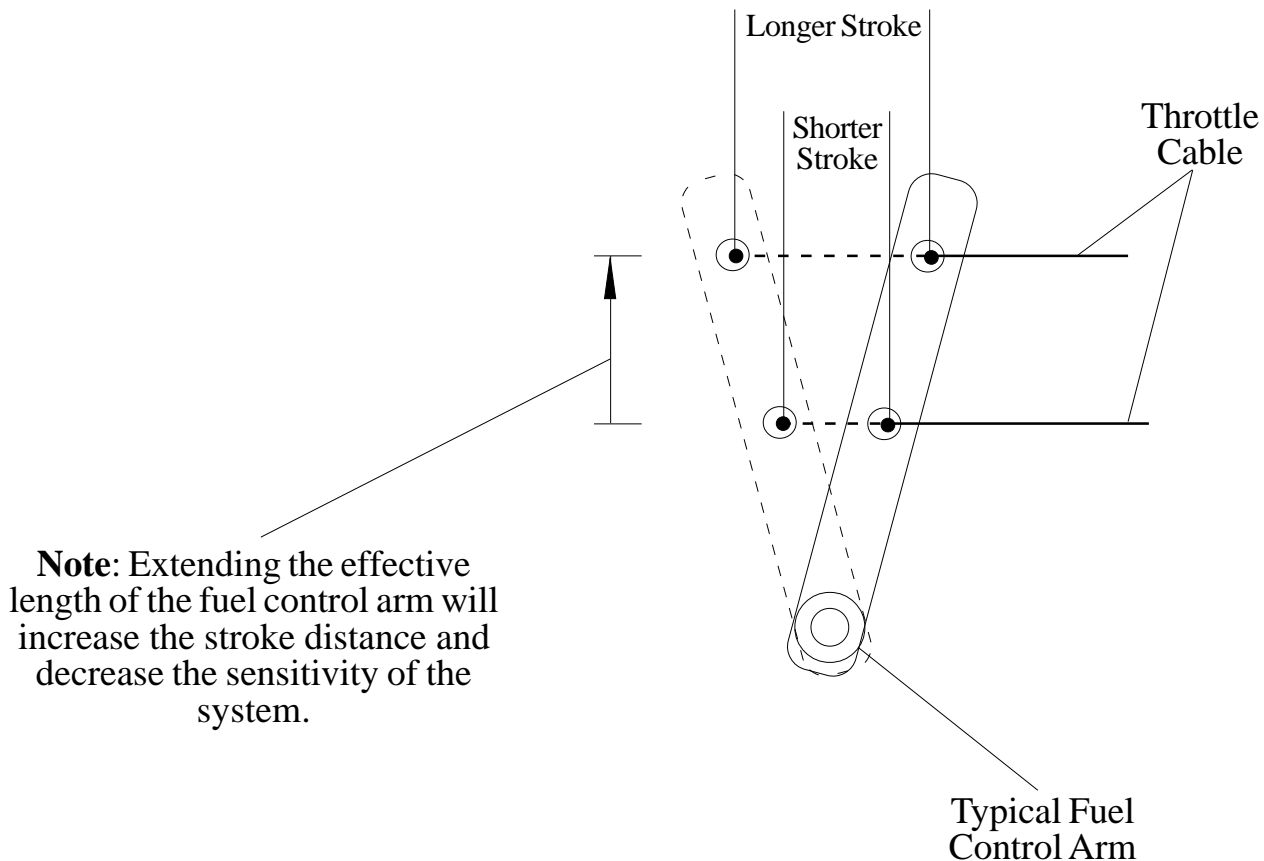

Figure 4. Fuel Control Arm

## Installation

1. Place the throttle servomotor in position and secure.

**Note:** The total motion of the linear actuator rod is approximately 1.85 inches. The motion of the fuel control arm must be more than 1.85 inches to prevent damage to the arm. It is recommended that the fuel control arm have a two inch stroke at the point the cable attaches.

2. Connect the throttle cable to the linear actuator rod and the fuel control arm.
3. Test the motion of the fuel control arm by operating the servomotor linear actuator rod to its minimum and maximum positions. Ensure that the fuel control arm operates freely. (Connect +12 VDC to red wire and ground to black wire to extend actuator rod, reverse wires to retract rod.)
4. Connect the 2-pin connector to the servomotor cable. (Refer to Wiring section.)

**Note:** The throttle cable is not supplied with the throttle servomotor.

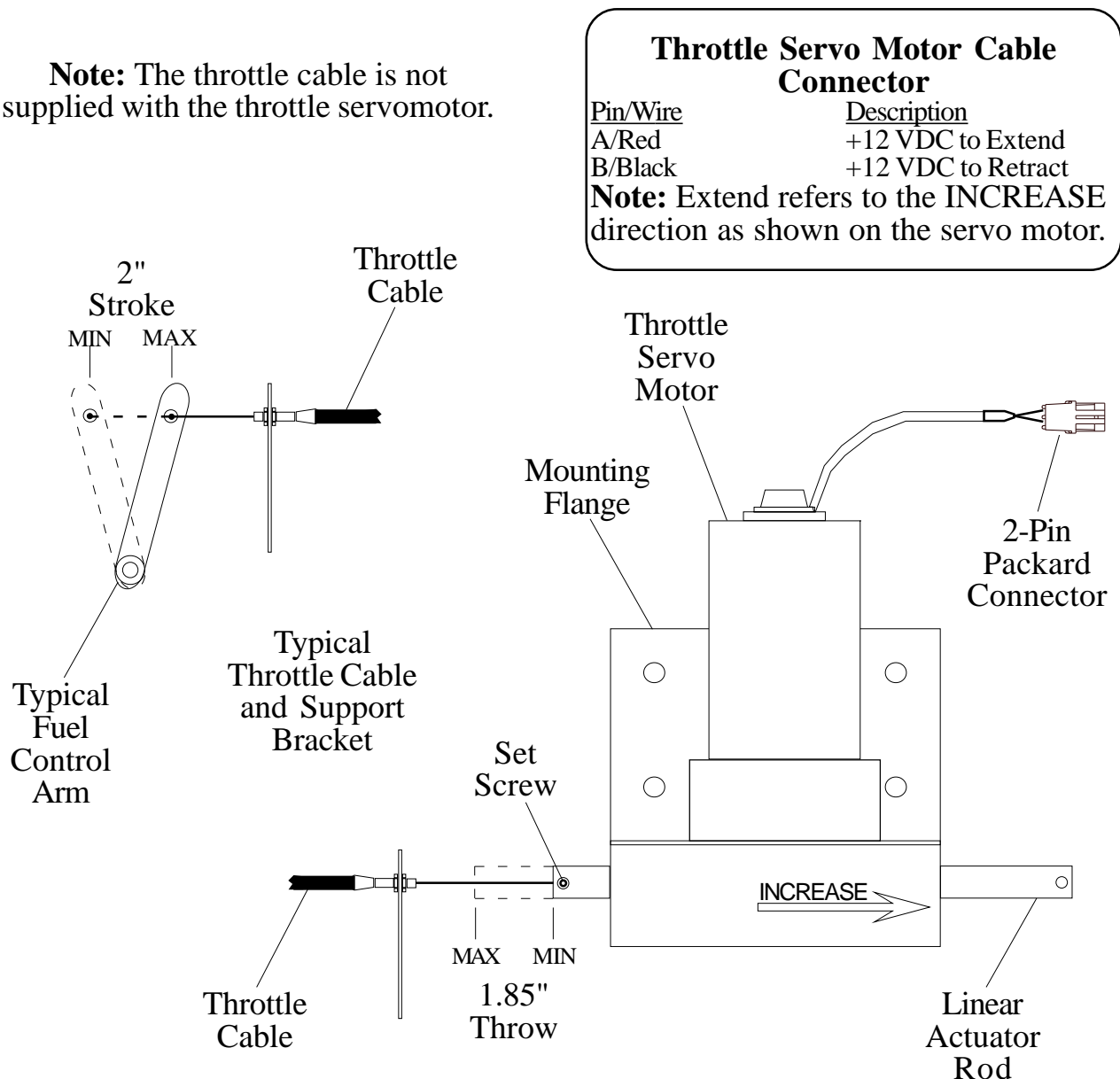

**Figure 5. Throttle Servo Motor**

## Install Optional High Idle

The High Idle Kit (FRC part number XE-PR38HC) provides the necessary components needed to install this option including a DPDT switch, 2500 ohm potentiometer, an indicator light, two diodes, and a cable.

The high idle cap may be installed on the end of the control module high idle 3-pin Deutsch connector. This cap is removed to install the high idle cable.

**Note:** Refer to the high idle calibration procedure after the installation is complete to adjust the 2500 ohm potentiometer for high idle engine RPM.

Install the potentiometer in a location that will allow access to adjust it during the calibration procedure.

For wiring of the high idle components refer to Figure 7. Optional High Idle Schematic.

## OPERATION

On power up the **PRO-S** will be in the pressure mode of operation. The **SETTING** display will show **IdLE**. If there is a problem, the **SETTING** display will show an error code. Refer to the Diagnostics section for error code descriptions.

**The minimum pump discharge pressure must be greater than 15 PSI for the PRO-S governor to take control of engine speed.**

No variation in discharge pressure or RPM will occur when changing between pressure and RPM modes.

### INCREASE/DECREASE Buttons

The **INCREASE** and **DECREASE** buttons are used to change pressure and RPM settings or program preset values. The rate and amount the numbers change when a button is pressed depends on the mode and how long the button is held.

In Pressure Mode. Press either button momentarily to change the pressure setting by 1 PSI. Press and hold the button for more than 2 seconds and the pressure setting will change by 5 PSI twice and then by 10 PSI until the button is released.

In RPM Mode. Press either button momentarily to change the RPM setting by 10 RPM. Press and hold the button for more than 2 seconds and the RPM setting will change by 50 RPM twice and then by 100 RPM until the button is released.

### Switching Between Operating Modes

- No variation in discharge pressure or RPM will occur when changing between pressure and RPM modes.
- When changing to RPM mode, the RPM setting will be the RPM that the pump was operating at in pressure mode.
- When changing to pressure mode the pressure setting will be the pressure that the pump was operating at in RPM mode.

When the **PRO-S** **SETTING** display shows **IdLE**:

Press the mode button and the **PRO-S** switches modes immediately.

When the **PRO-S** **SETTING** display shows a value (operating at some setting):

Press and hold the mode button for 3 seconds and the **PRO-S** changes modes. (This is to avoid an accidental change over if the buttons get bumped.)

### High Pump Discharge Pressure at Engine Idle

Once the governor has set the engine to idle, it can do no more to reduce discharge pressures. To reduce discharge pressure the pump operator can gate incoming water, reduce pressure at the intake relief valve, gate discharges, or disable the pump.

---

## Pressure Mode Operation

In the pressure mode of operation the **PRESSURE LED** will be on. The **PRO-S** will maintain a constant discharge pressure. It will adjust the engine RPM automatically to compensate for variations in pressure.

**Note:** When changing from RPM mode to pressure mode the pressure setting will be the pressure that the pump was operating at in RPM mode.

1. Press and hold **PRESSURE** mode button for 3 seconds.

Result: **PRESSURE LED** goes on.

2. Press **PRESET** and/or **INCREASE/DECREASE** button to select the operating discharge pressure.
3. Press **IDLE** button to bring engine to idle RPM.

Result: **SETTING** display shows **ldLE**.

### Switching Supply Water

When switching the water supply source from tank to hydrant, draft to hydrant, or draft to relay, water flow through the pump can become turbulent and the positive pressure from these sources may generate a sudden pressure surge. It is recommended that the **PRO-S** be set in RPM mode before changing the water supply source.

### No or Low Supply Water

There are situations during pump operations when there may be no or low supply water. This can be due to an empty water tank, a problem on the intake line, or when switching the water supply source.

In pressure mode the **PRO-S** will increase the engine RPM and attempt to maintain the selected pressure setting. If the discharge pressure drops below 45 PSI but stays above 15 PSI the **PRO-S** will go into a low water cycle. It will set the engine to 1100 RPM, if the pressure does not rise above 45 PSI in 7 seconds (30 for **PRO-S 3**) the **PRO-S** will set the engine to idle RPM for seven seconds. The **PRO-S** will repeat the low water cycle as long as the discharge pressure is between 15 and 45 PSI.

If the discharge pressure drops below 15 PSI the engine RPM will go to idle and the **SETTING** display will show the selected setting. When the discharge pressure rises above 45 PSI the **PRO-S** will resume control at the previous selected setting.

### Opening/Closing Discharge Valves

In pressure mode the **PRO-S** will maintain the pressure setting regardless of the number of discharge lines that are opened or closed providing there is a sufficient water supply. As lines are opened the discharge pressure will start to drop and the **PRO-S** will raise the engine RPM to maintain the required pressure. As lines are closed the discharge pressure will start to rise and the **PRO-S** will lower the engine RPM to maintain the required pressure.

## RPM Mode Operation

In the RPM mode of operation the RPM LED will be on. The **PRO-S** will maintain a constant engine RPM.

The pump discharge pressure can vary but, as a safety feature, the **PRO-S** limits the increase in pressure to 30 PSI over the last established PSI value. As the discharge pressure approaches this limit the **PRO-S** will automatically lower the RPM to prevent a high pressure surge. The RPM LED will blink as the **PRO-S** sets a lower RPM. This lower RPM will be the new operating RPM setting. Pressing any button will stop the blinking LED.

**Note:** When changing from pressure mode to RPM mode the RPM setting will be the RPM that the pump was operating at in pressure mode.

1. Press and hold RPM mode button for 3 seconds.

Result: RPM LED goes on.

2. Press PRESET and/or INCREASE/DECREASE button to select the operating RPM.
3. Press IDLE button to bring engine to idle RPM.

Result: SETTING display shows IdLE.

## Change Preset Setting (Pressure or RPM)

The preset button allows the operator to go to a pre-programmed pump pressure or engine RPM during operations. The setting will be shown on the SETTING display. This procedure is to change the setting in the program.

**Note:** The engine must be running and the pump engaged interlock circuit must be closed.

1. Press IDLE button.

Result: SETTING display shows IdLE.

2. Press PRESSURE or RPM mode button to select the setting to be changed.

Result: LED indicator goes on for mode selected.

**Note:** The RPM display must show IdLE before changing the preset.

3. Press and hold PRESET button. (Continue to hold through step 4.)

Result: SETTING display flashes previous programmed preset.

4. Press INCREASE or DECREASE button to change preset setting.

5. Release PRESET button.

Result: The new preset is programmed. SETTING display shows IdLE.

---

# System Options

## High Idle

**Note:** If the optional remote high idle kit is not being installed, ensure that the high idle cap (supplied) is installed on the end of the control module high idle cable.

The RPM that the engine will run at when the high idle circuit is engaged is set by adjusting the 2500 ohm potentiometer. Refer to Calibration section if the potentiometer has to be adjusted.

To engage the high idle, place the high idle switch to ON. The high idle indicator light will go on and the engine will run at the set RPM. The **PRO-S** SETTING display will show the high idle RPM.

With the high idle switch set to on, the PRO-S controls will operate normally for RPMs above the high idle RPM. The **DECREASE** and **IDLE** buttons will not lower the engine RPM below the high idle setting.

**It is recommended that the high idle switch be set to OFF when operating the pump.**

**CAUTION:** The high idle switch must be off before shutting the engine off. Failure to do so could result in damage to equipment.

# CALIBRATION

## RPM Calibration (PRO-S 3, 6, and 8)

The following models of the PRO-S require the RPM control to be calibrated:

PRA203	Non-electronic diesel and gasoline engines
PRA206	Ford engines
PRA208	Scania engines

### Initial conditions

To perform the following calibration procedure a reference tachometer is needed to verify the correct engine RPM, the engine must be at idle RPM, and the SETTING display on the PRO-S must show IDLE.

1. Press RPM mode button.

Result: RPM LED indicator goes on.

2. Press IDLE button two times.

Result: SETTING display shows CAL flashing.

**Note:** Confirmation of selecting the calibration mode has to be input within five seconds of CAL flashing in the SETTING display.

3. Press IDLE button two times again to confirm selection of calibration mode.

Result: SETTING display shows CAL steady.

4. Press PRESET button.

Result: SETTING display alternately flashes SET and 1200.

5. Press INCREASE/DECREASE button to set reference tachometer to 1200 RPM.

Result: The engine RPM will respond to changes of the INCREASE/DECREASE buttons.

6. Press PRESET button.

Result: Engine RPM goes to idle.

SETTING display shows IdLE.

RPM calibration is complete.

---

## High Idle Option Calibration

The RPM that the engine will run at when the high idle circuit is engaged is set by adjusting the 2500 ohm potentiometer.

1. Loosen the lock nut on the potentiometer.
2. Place the high idle switch to ON.
3. With a small screw driver adjust the wiper arm on the potentiometer to set the engine RPM. (Use a reference tachometer monitor engine speed.)
4. Tighten the lock nut on the potentiometer. Ensure the engine RPM does not change when the lock nut is tightened.
5. Place the high idle switch to OFF.

## 3rd Gear Lock-up RPM Calibration (Ford 6.0L)

The 3rd gear lock-up is factory set at 1200 RPM. This procedure is to change the setting in the program.

**Note:** The engine must be running and the pump engaged interlock circuit must be closed.

1. Press IDLE button.  
Result: SETTING display shows IdLE.
2. Press RPM mode button to select RPM mode.  
Result: RPM LED indicator goes on.

**Note:** The RPM display must show IdLE.

3. Press and hold PRESET button. (Continue to hold through step 5.)  
Result: SETTING display flashes the programmed preset.
4. Press and release RPM mode button.  
Result: SETTING display shows programmed lock-up RPM.
5. Press INCREASE or DECREASE button to change RPM setting.
6. Release PRESET button.

Result: The new 3rd gear lock-up RPM is programmed. SETTING display shows IdLE.

## DIAGNOSTICS

The information listed in Table 2 is to aid in troubleshooting a problem. The diagnostic code will be shown in the **SETTING** display on the control module.

**Table 2. Diagnostic Codes**

<b>Code</b>	<b>Problem</b>	<b>Probable Cause</b>
<b>E1</b>	No communication on datalink	>No voltage at the interlock input
		>Datalink cable not connected / incorrectly wired
		>Broken wire / bad connector contact on datalink cable
<b>E2</b>	Bad data on datalink	>Noise interference (radio frequency or electrical)
<b>E3</b>	[Electronic engines] RPM data not detected on datalink	>Datalink cable not connected / incorrectly wired >Engine not running / ignition key on
	[Non-Electronic engines] RPM signal not detected	>Broken wire / bad connector contact on alternator cable
<b>E4</b>	Cannot transmit over datalink (No response from ECM)	>No voltage at the interlock input
		>Internal datalink problem - bad control module
		>Datalink shorted
<b>E5</b>	Discharge pressure transducer not detected	>Transducer cable not connected
		>Broken wire / bad connector contact on transducer cable
		>Defective pressure transducer
<b>E6</b>	N/A	N/A
<b>E7</b>	Not able to raise pump pressure from idle to set pressure	>Low supply water, intake line problem, valve closed, pump not primed, etc.
		>Defective pressure transducer

# WIRING

The following figures include the schematics, wiring diagrams, block diagrams, and cables for the PRO-S series governors.

**Note:** If optional 24 VDC unit is installed references to +12 VDC will be +24 VDC.

## Power

From Control Module  
Power Supply 3-Pin  
Deutsch Connector

Power Supply Cable Connector	
Pin/Wire	Description
A/Red	+12 VDC*
B/Black	Ground
C/White	Interlock Circuit

\* +24 VDC with option.

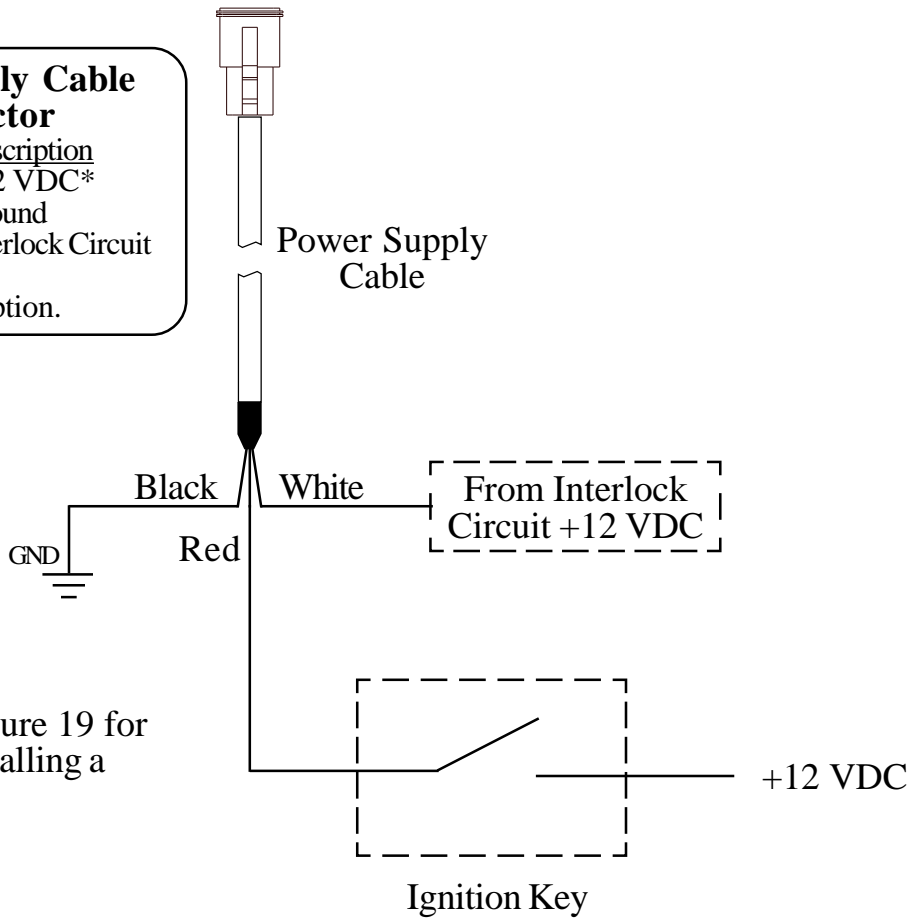

**Note:** Refer to Figure 19 for information on installing a flyback diode.

**Note:** The interlock circuit will ensure that specific safety conditions are met before the pump becomes operational. The interlock circuit may include relays, switches, and/or indicator lights for the following conditions:

- Parking Brake On
- PTO Engaged
- Transmission In Drive/Neutral
- High Idle
- OK To Pump
- Throttle Ready

**Figure 6. PRO-S Supply Power Wiring**

# High Idle

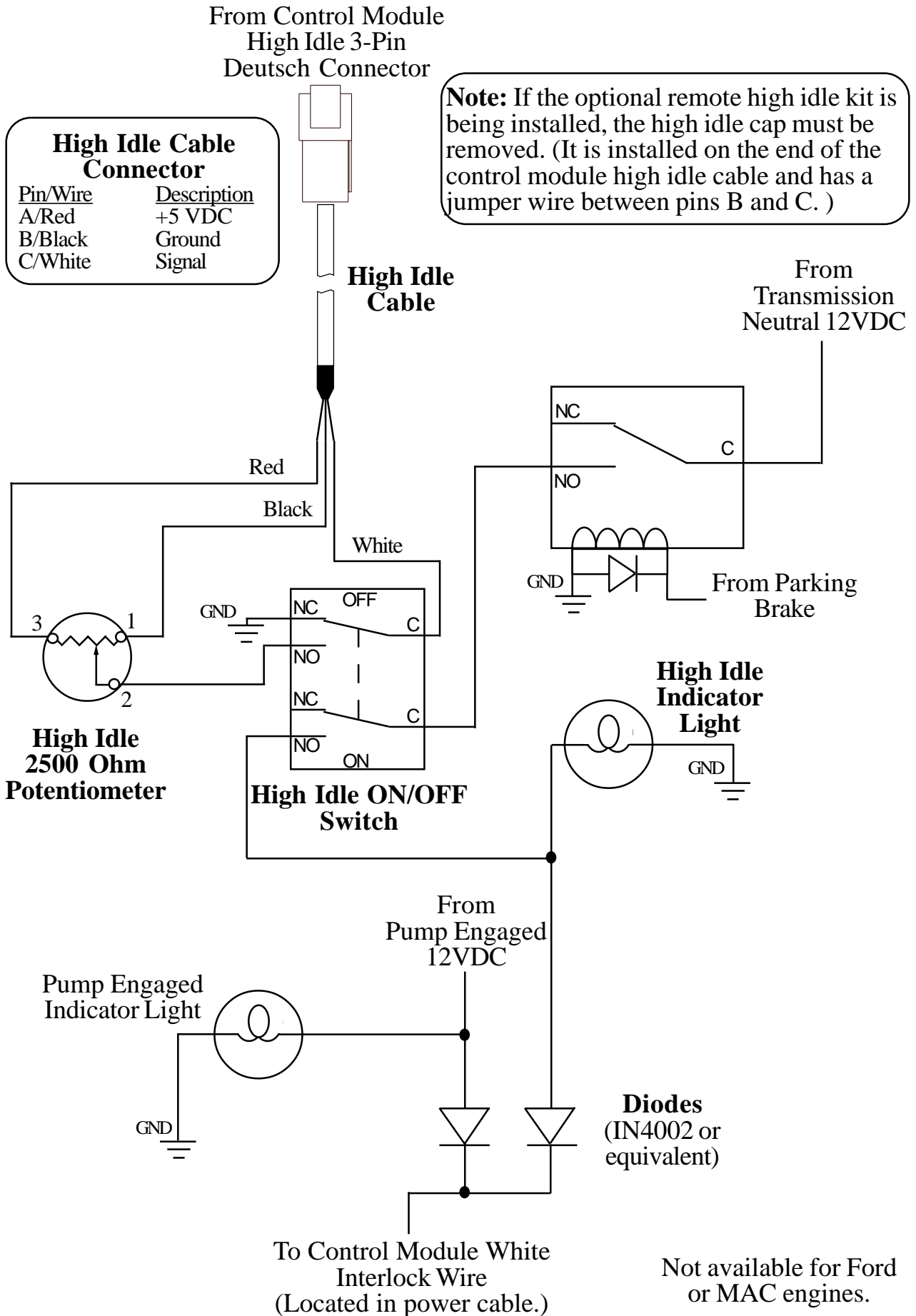

**Figure 7. Optional High Idle Schematic**

# Pressure Sensor

<b>Pressure Sensor Cable 4-Pin Deutsch Connector</b>	
<u>Pin/Wire</u>	<u>Description</u>
1/Red	Supply Voltage
2/Black	Ground
3/White	Signal Output
4/Yellow	Cable Shield

<b>Pressure Sensor Cable 3-Pin Sensor Connector</b>	
<u>Pin/Wire</u>	<u>Description</u>
A/Black	Ground
B/Red	Supply Voltage
C/White	Signal Output

From Control Module  
Pressure Sensor 4-Pin  
Deutsch Connector

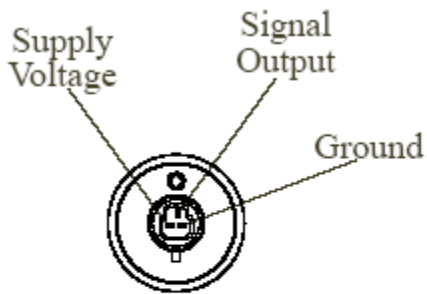

Pressure Sensor  
(Top View)

Pressure Sensor  
Side View

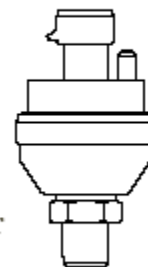
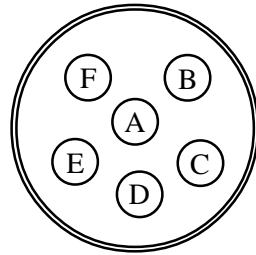

**Figure 8. Pressure Sensor Wiring**

# Common OME Diagnostic Connectors

Typical 6-pin Deutsch diagnostic connector.  
Commonly found under the driver side dashboard.

Pin A J1587 Datalink Positive  
Pin B J1587 Datalink Negative



FRONT  
VIEW

Typical 9-pin Deutsch Diagnostic Connector.  
Commonly found under the driver side dashboard.

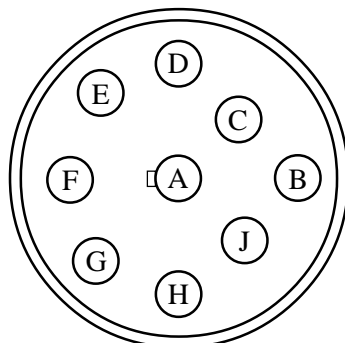

FRONT  
VIEW

<b>9-Pin Connector</b>	
<u>Pin</u>	<u>Description</u>
A	BATTERY GROUND
B	+12 VDC
C	J1939 DATA LINK (+)
D	J1939 DATA LINK (-)
E	J1939 SHIELD
F	J1587 DATA LINK (+)
G	J1587 DATA LINK (-)
H	PLUG
J	PLUG

**Figure 9. Common OEM Diagnostic Connectors**

# Cummins PRA201 Cables

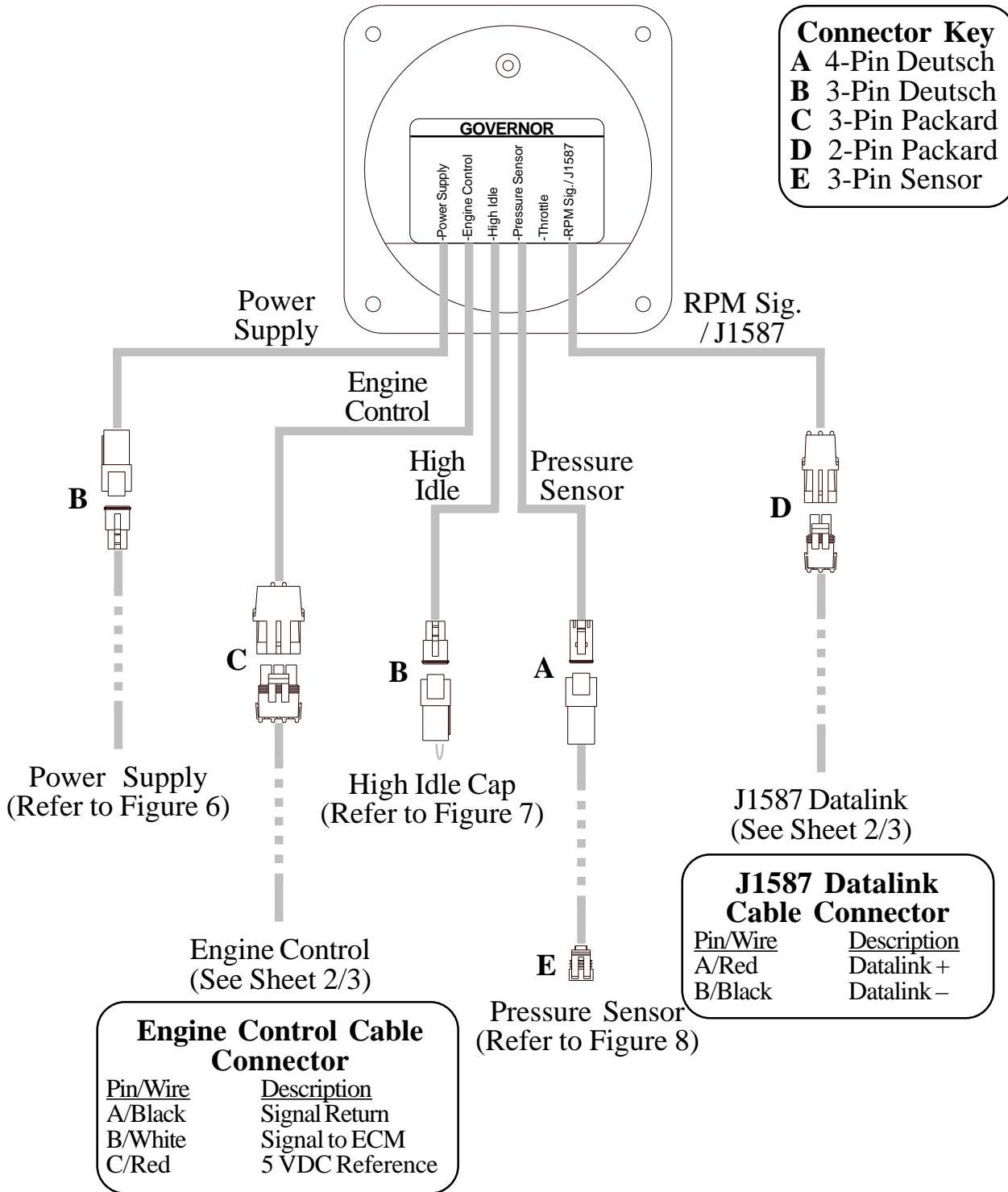

**Figure 10. Cummins PRA201 Wiring (Sheet 1 of 3)**

# Cummins Harness Connections

## Interface Information

The ECM Remote Acceleration Option has to be set to ON. The diagnostic tool cannot be used to do this, an Insight service tool must be used. Refer to an authorized dealer to program this option.

**2007**  
 ISB07/ISC07/ISL07 CM 2150D Model Engines

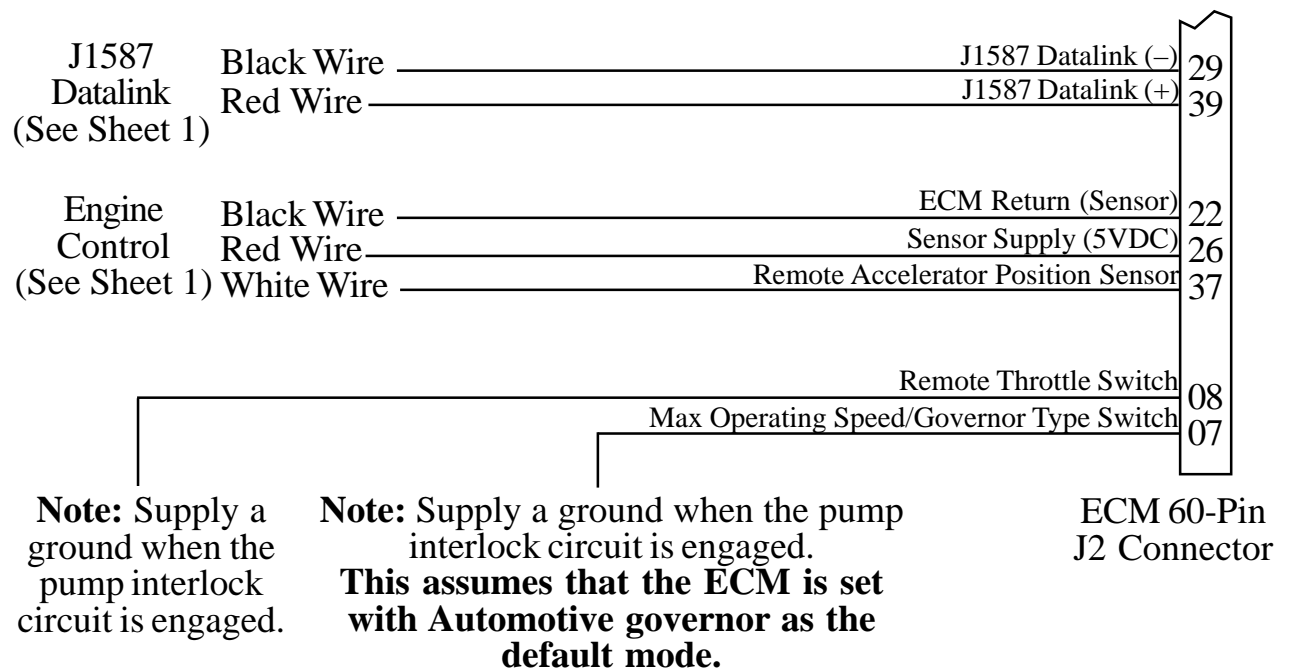

**Figure 10. Cummins PRA201 Wiring (Sheet 2 of 3)**

**2007**  
**ISM07 CM 876 Model Engines**  
**2004 to 2006**  
**ISB02/ISC03/ISL03 CM850 Model Engines**  
**ISM02 CM870 Model Engines**

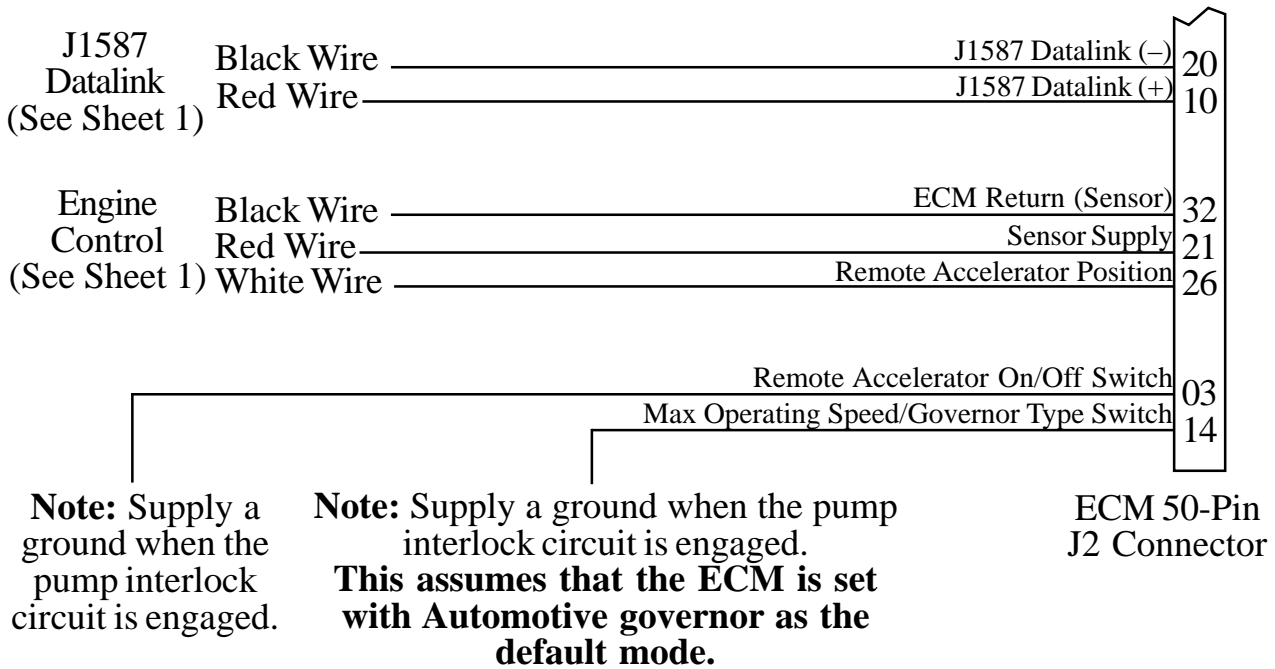

**Figure 10. Cummins PRA201 Wiring  
 (Sheet 3 of 3)**

This page intentionally left blank.

# Detroit Diesel (Series 50 and 60) PRA202 Cables

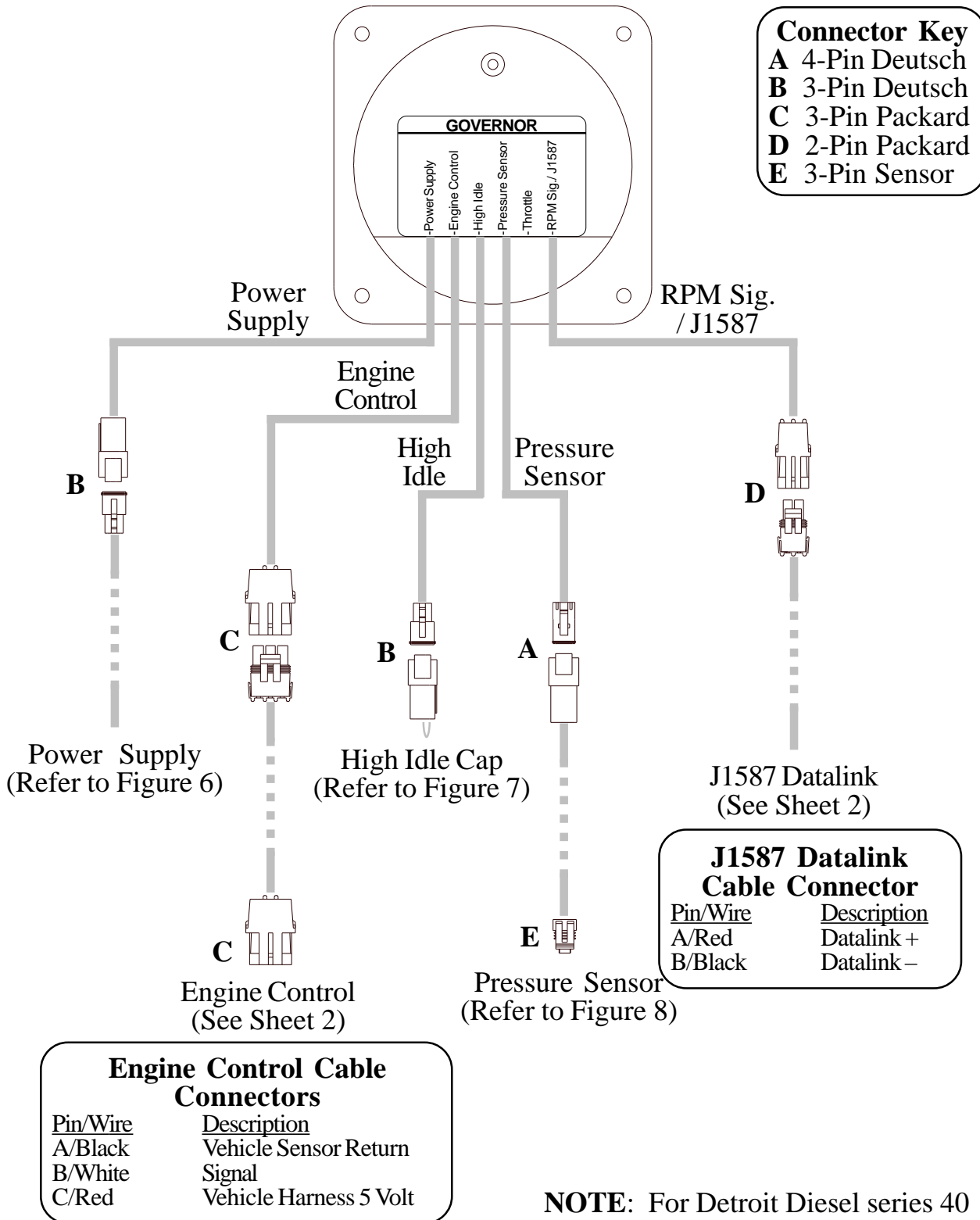
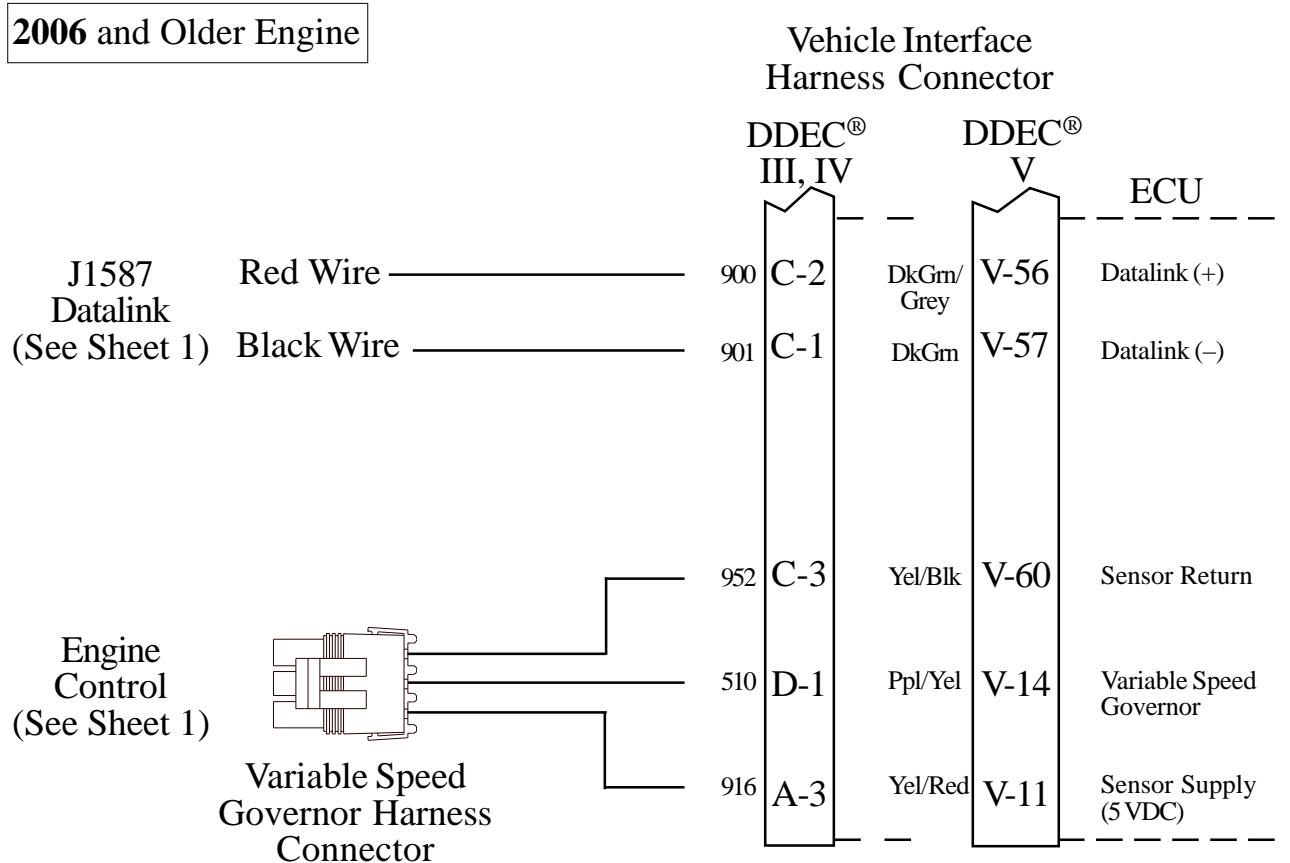
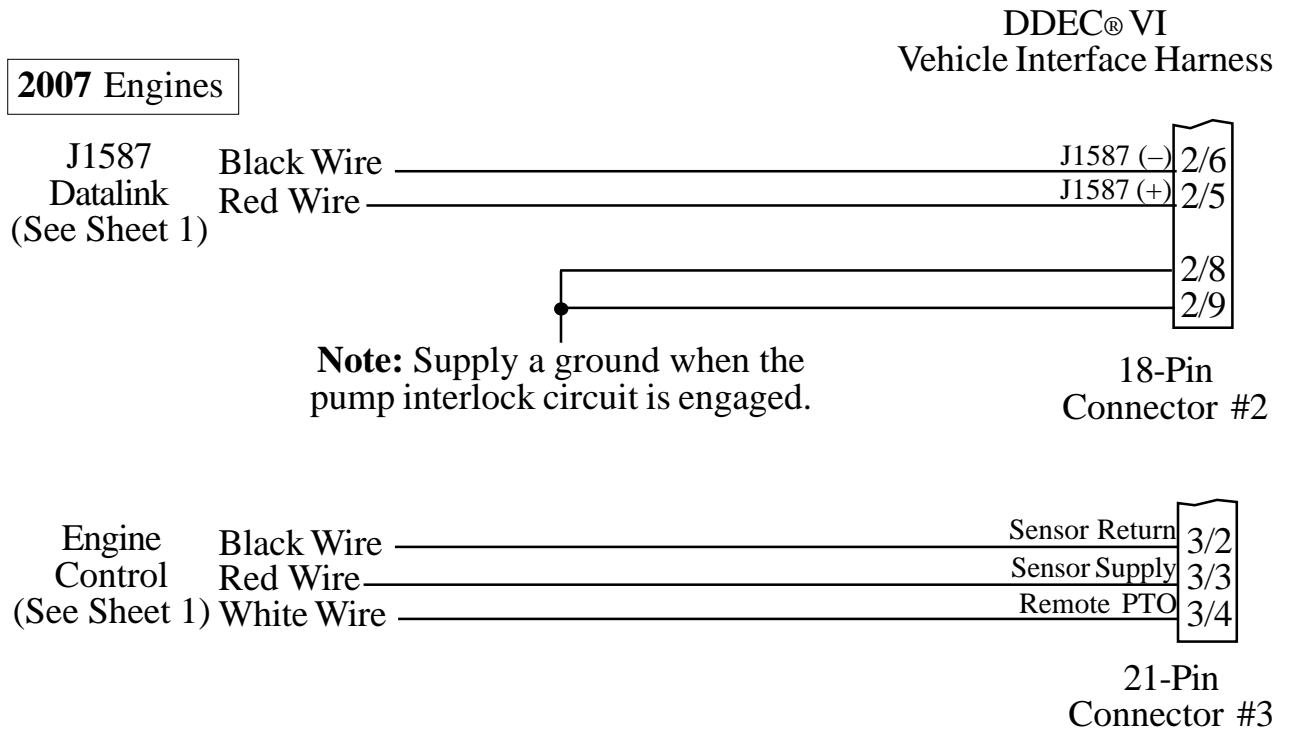

**Figure 11. Detroit Diesel (Series 50 and 60) PRA202 Wiring (Sheet 1 of 2)**

# Detroit Diesel (Series 50 and 60) Harness Connections

## Interface Information

Not available for Detroit Diesel engine model year 2008 and newer.



**Figure 11. Detroit Diesel (Series 50 and 60) PRA202 Wiring (Sheet 2 of 2)**

# Non-Electronic Engine PRA203 Cables

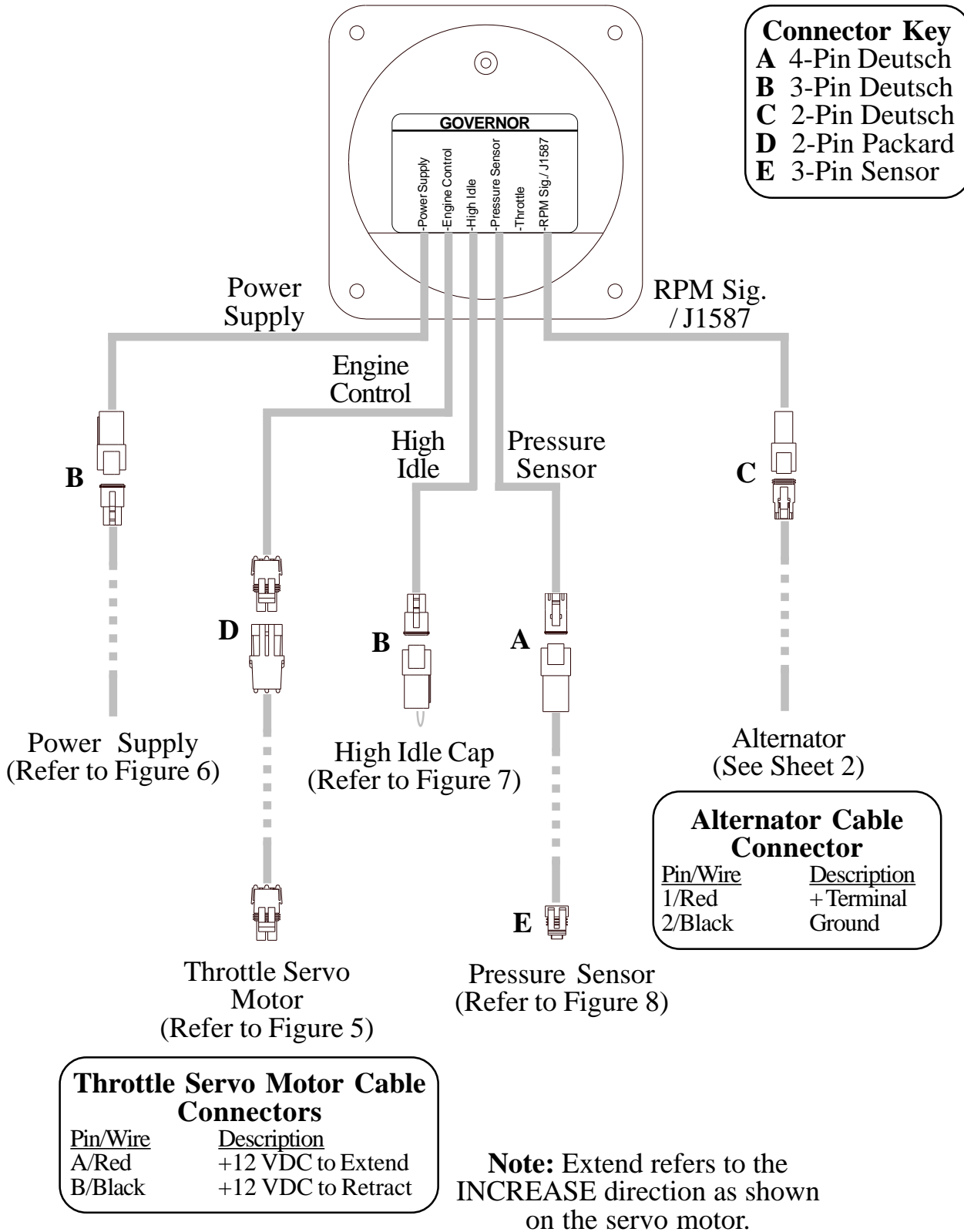

**Figure 12. Non-Electronic PRA203 Wiring (Sheet 1 of 2)**

---

# Non-Electronic Harness Connections

## Interface Information

Connect the red alternator cable wire to the small positive (+) terminal on the alternator. (Some names used for this terminal: Alternator Tap, Stator Tap, A/C Tap, Tachometer Signal Connection, Tach Output, Tach Terminal.) Do not connect the red wire to the large battery (BAT) terminal. Connect the black wire to chassis ground.

**Figure 12. Non-Electronic PRA203 Wiring  
(Sheet 2 of 2)**

# Navistar PRA204 Cables

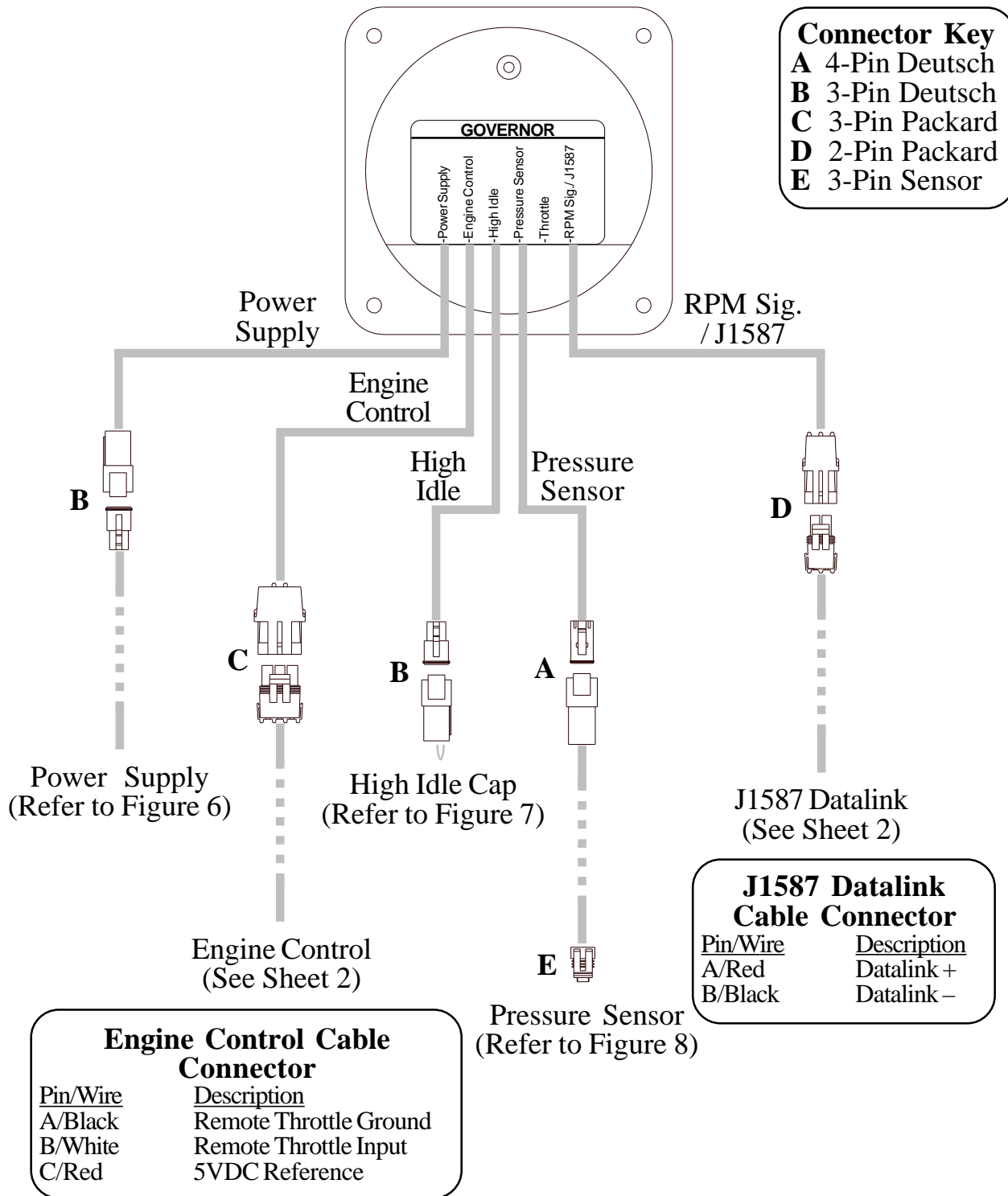

**Figure 13. Navistar PRA204 Wiring (Sheet 1 of 2)**

# Navistar Harness Connections

## Interface Information

The ECM must be programmed for a remote throttle input. When using code 12VZA or 12VXY, the following parameters need to be set:

PTO-REMOTE-PEDAL to 1-Yes; PTO-REM-PEDAL-RTZ to 1-RTZ-not;

PTO-DISABLE-CAB-INTERFACE to 1-Yes; DRIVELINE-MODE to 1

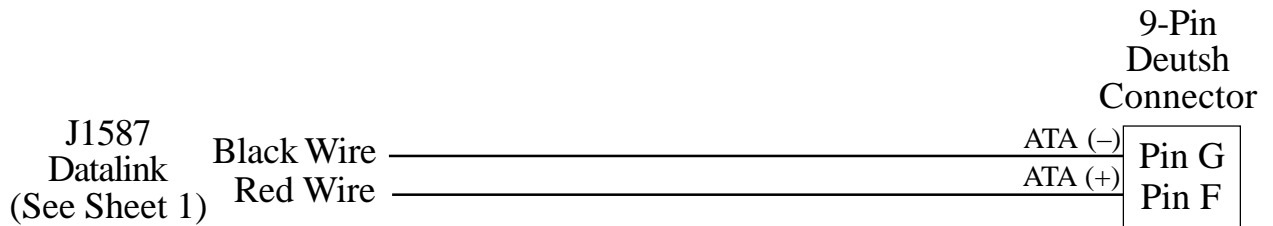

### 2007 and Newer Engines

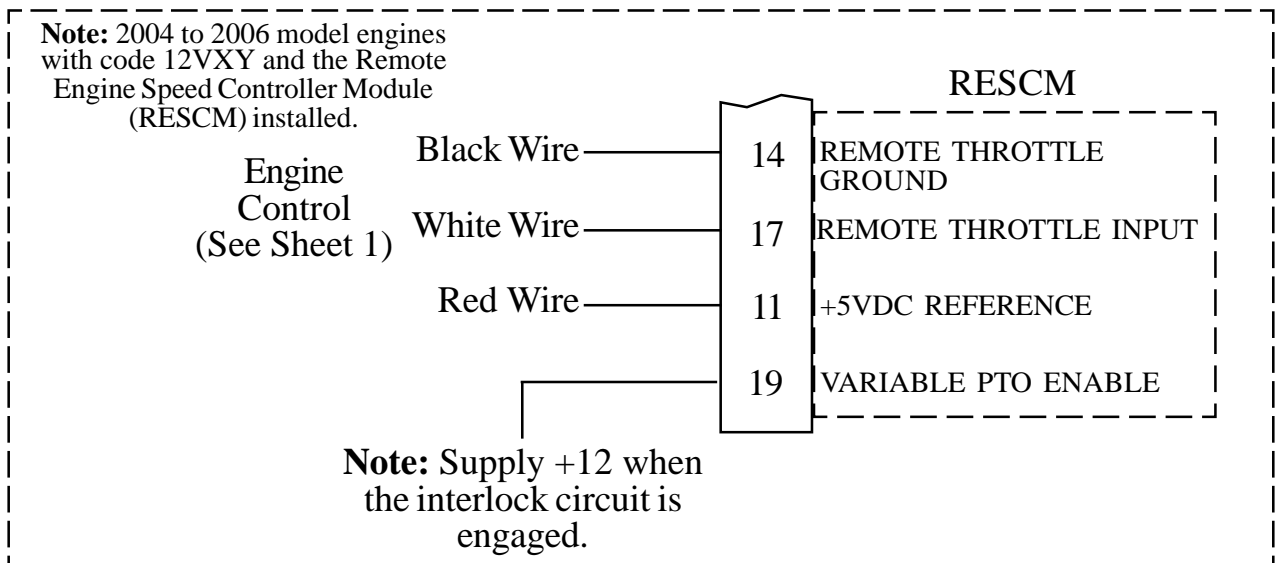
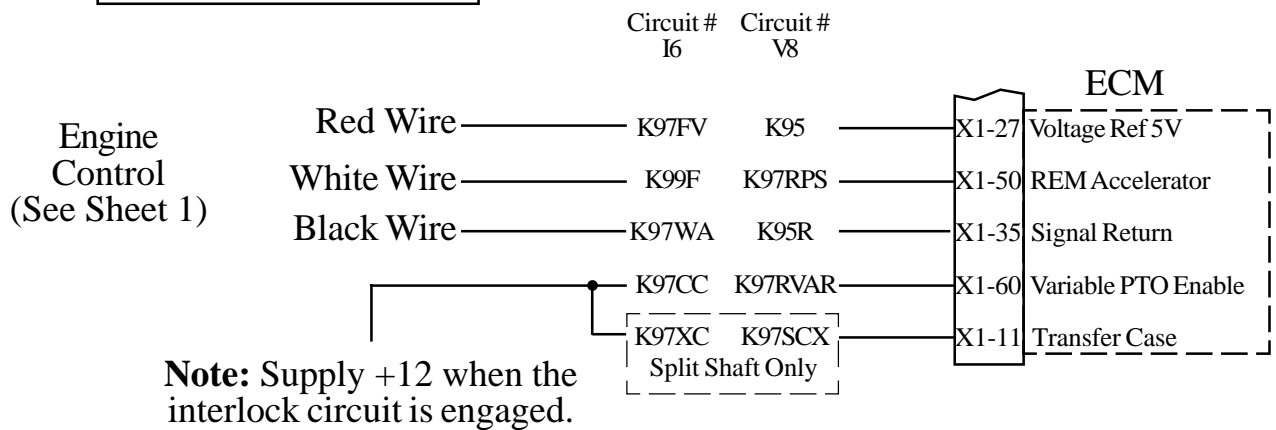

**Figure 13. Navistar PRA204 Wiring (Sheet 2 of 2)**

# Caterpillar PRA205 Cables

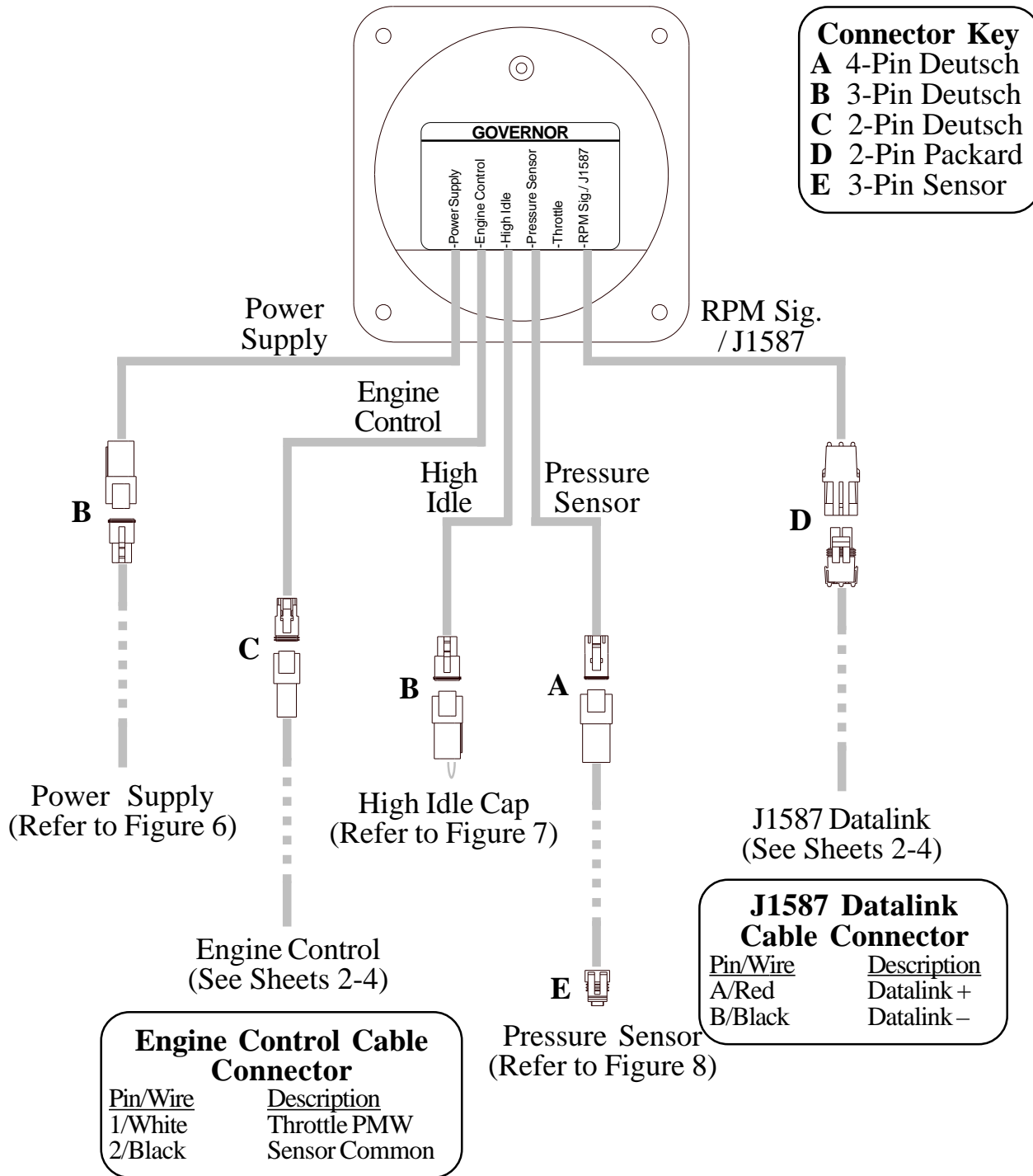

**Figure 14. Caterpillar PRA205 Wiring (Sheet 1 of 4)**

# Caterpillar Harness Connections

## Interface Information

The ECM Remote Throttle Option has to be enabled. Refer to an authorized dealer to program this option.

### C7,C9,C10,C11,C12,C13,C15 Engine Interface

Engines with 70-pin OEM connector.

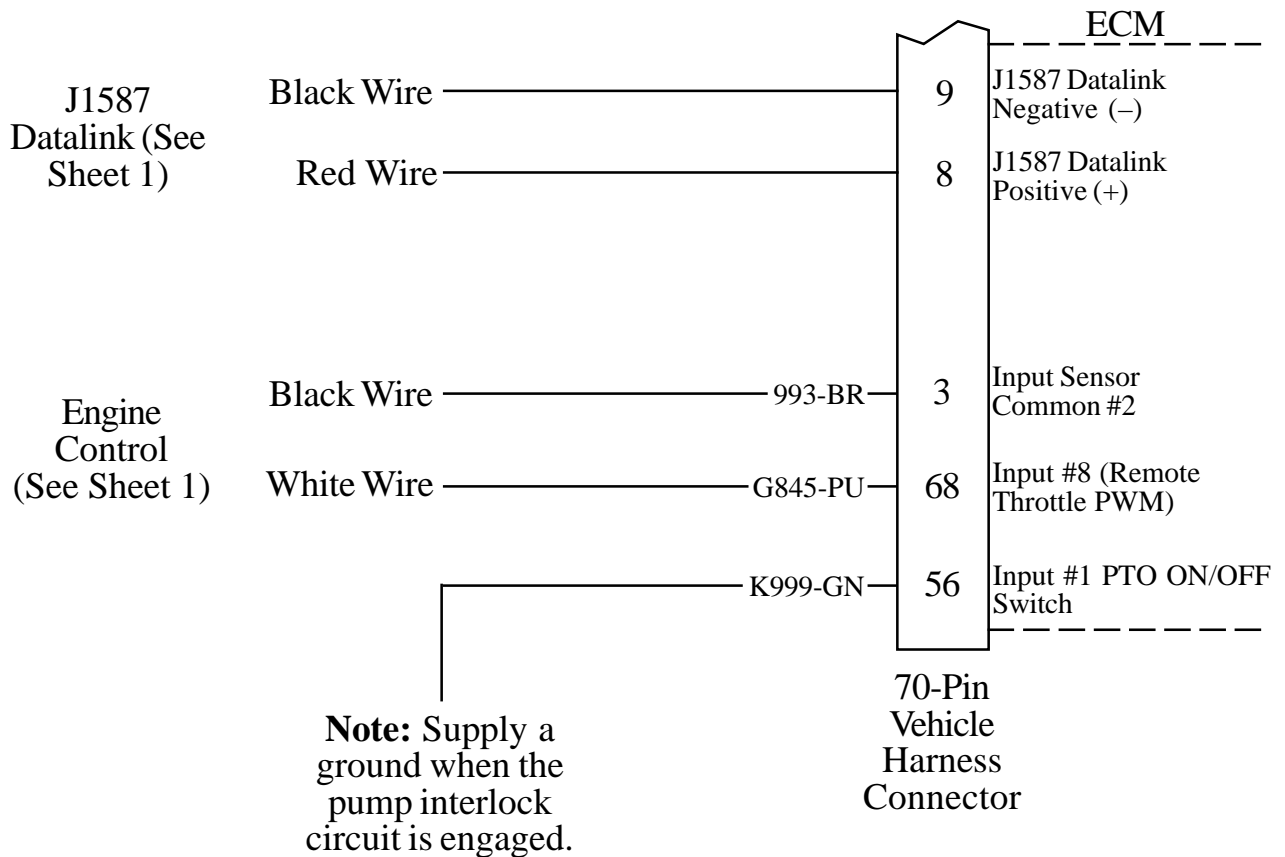

**Figure 14. Caterpillar PRA205 Wiring (Sheet 2 of 4)**

**C10, C12 Engine Interface**

Engines with 40-pin OEM connector.

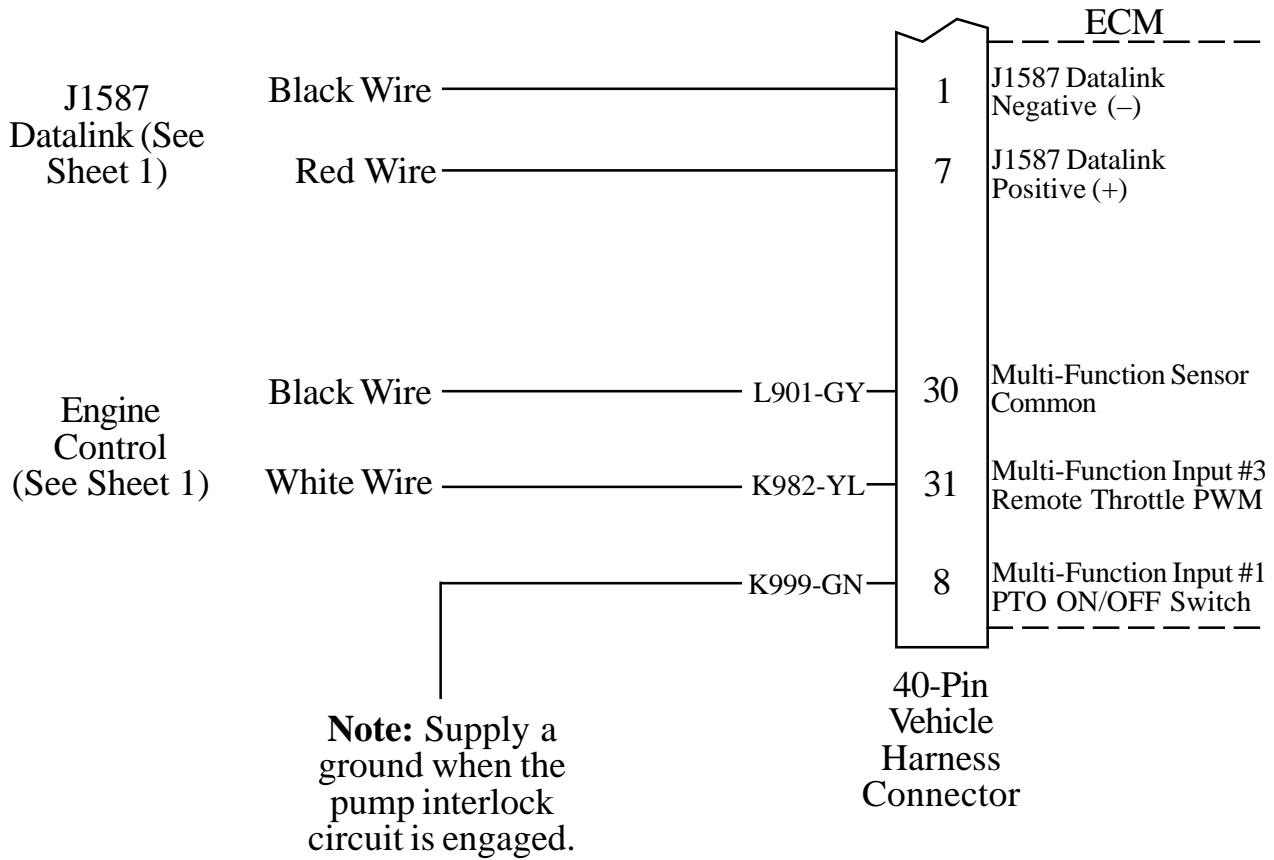
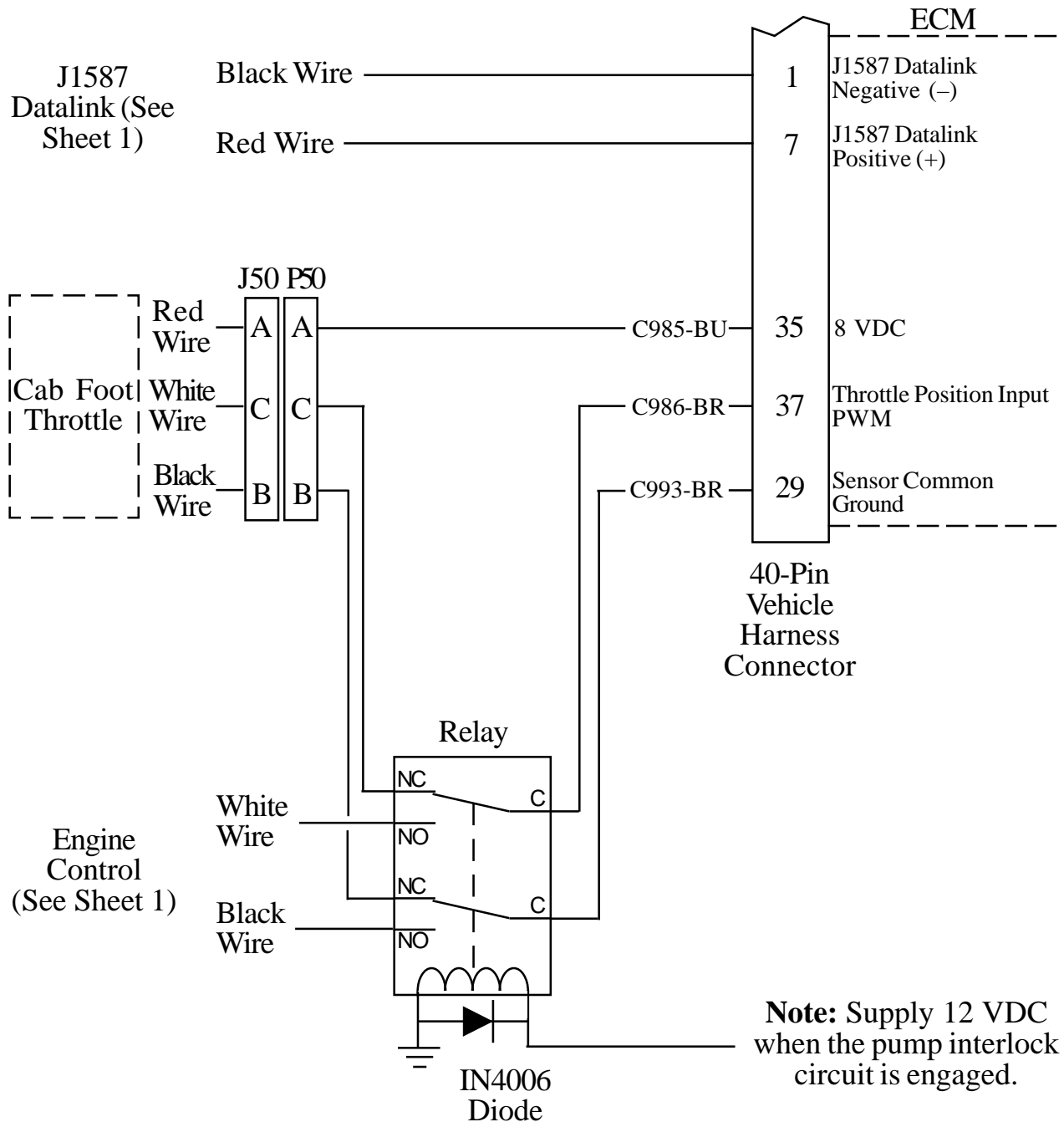

**Figure 14. Caterpillar PRA205 Wiring (Sheet 3 of 4)**

### Some Older Engine Interface

Engines with 40-pin OEM connector.

If the remote throttle option is not available in the ECM program, a relay needs to be installed to provide this capability. Wire the relay into the cab foot throttle harness, connect the PRO-S Engine Control cable, and supply 12 volts to the coil form the pump interlock circuit. Refer to the wire diagram below.



**Figure 14. Caterpillar PRA205 Wiring (Sheet 4 of 4)**

# Ford PRA206 Cables

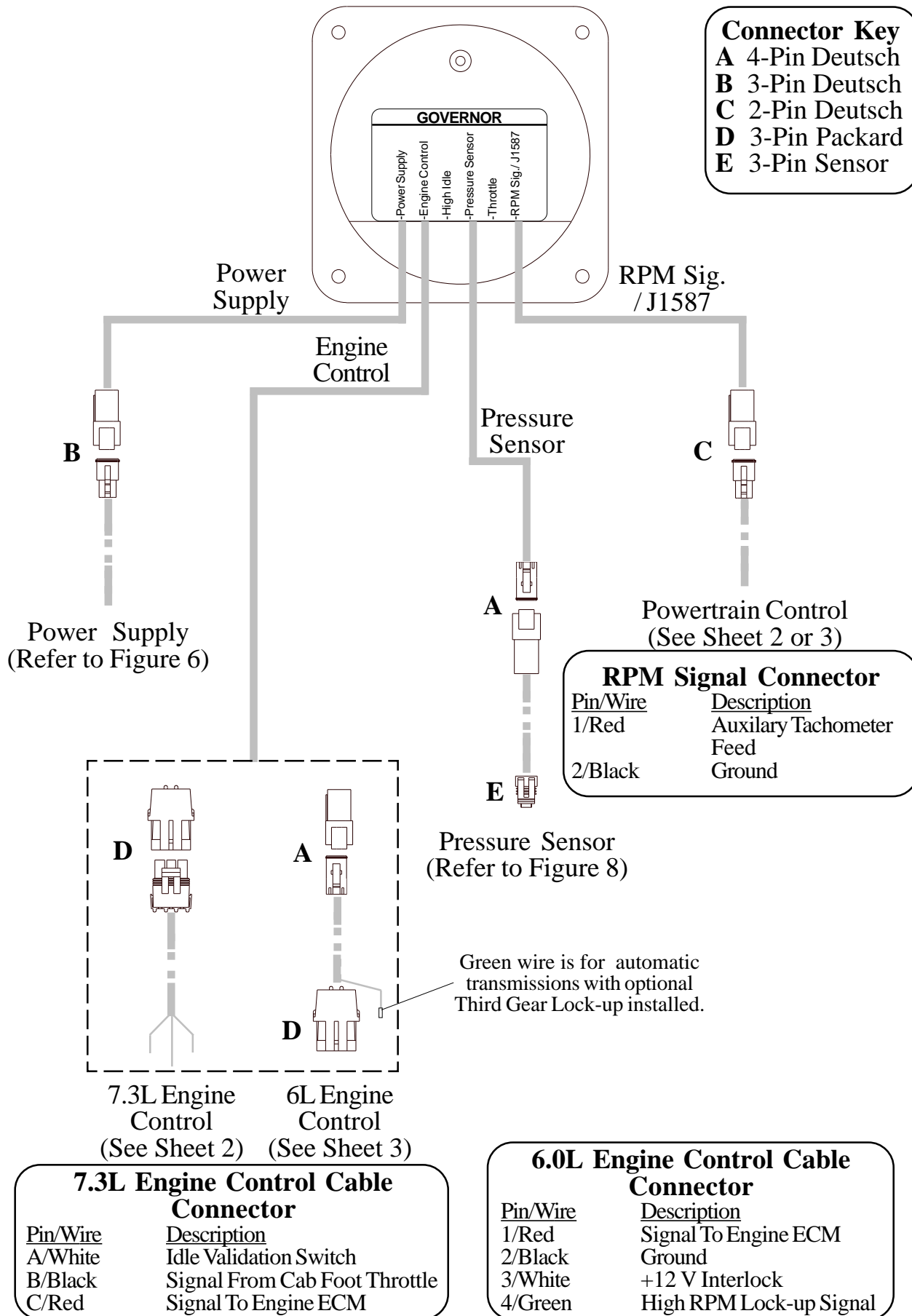

**Figure 15. Ford PRA206 Wiring (Sheet 1 of 4)**

# Ford Harness Connections

## Interface Information

### 7.3L Power Stroke Engine

The **PRO-S** Engine Control cable needs to be wired in series with the cab foot throttle. Use a voltmeter to determine which pins are Idle Validation and Engine Control Signal.

Idle Validation will be at ground. When the foot pedal is pressed it will rise to 12 VDC.

Engine Control Signal will be 0.6 volts at idle and rise to approximately 3.1 volts as the foot pedal is pressed.

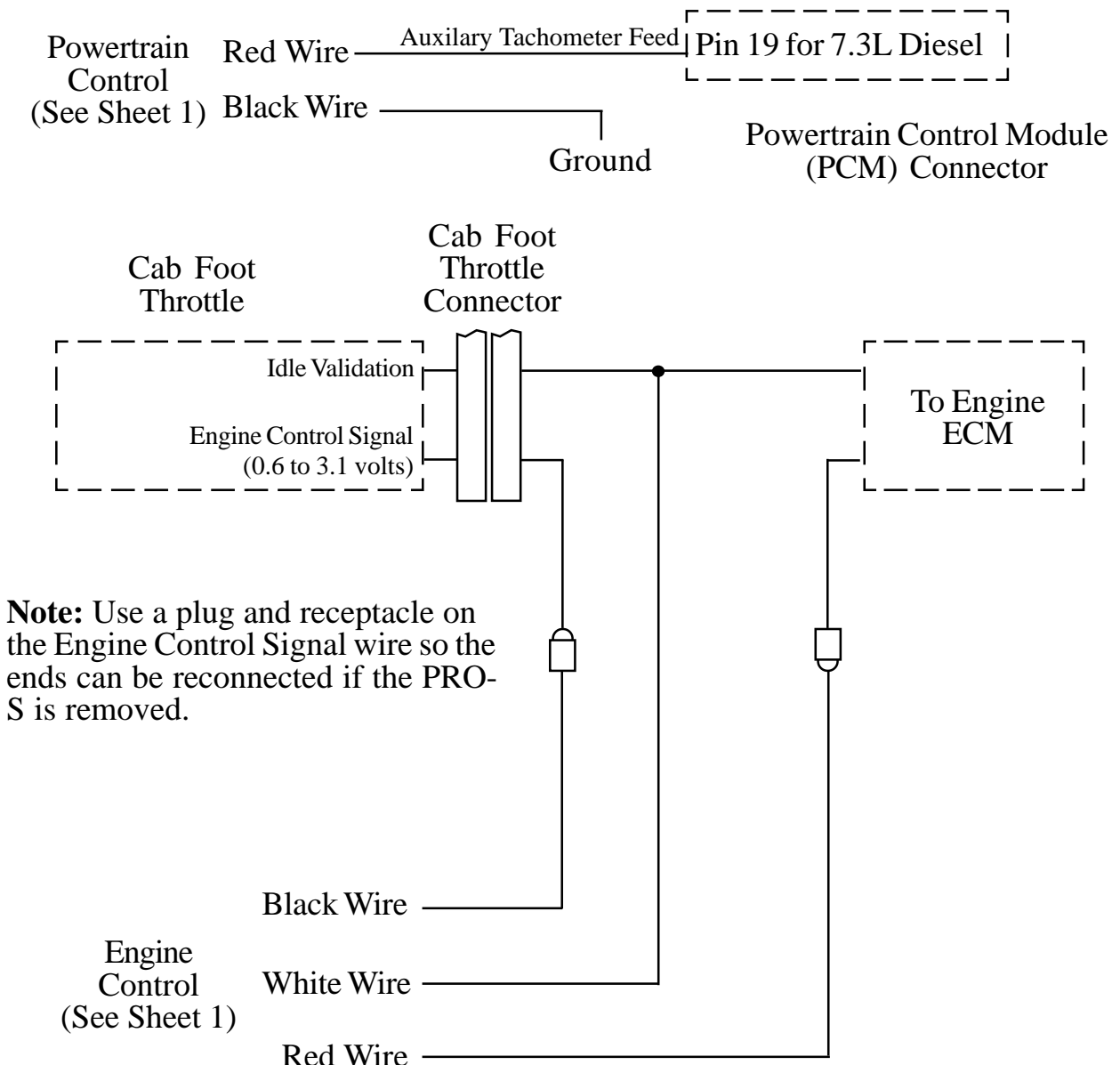

**Figure 15. Ford PRA206-A Wiring (Sheet 2 of 4)**

### 6.0L and 6.4L Diesel Engine

An adapter and cable assembly is needed to interface the PRA206 with the 6.0L engine. Two 6 pin connectors are provided and need to be spliced into the harness between the cab foot throttle and the ECM. Do not mount the adapter assembly in the engine compartment.

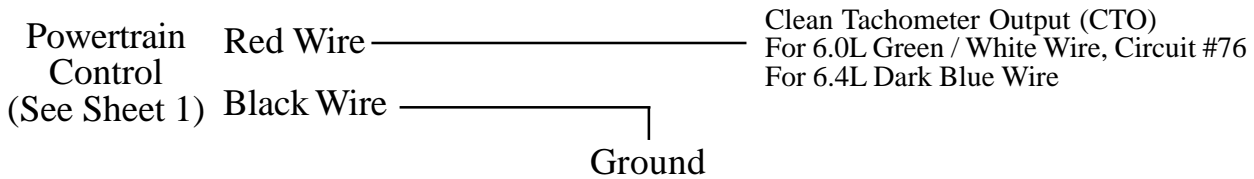

Engine Control (See Sheet 1)

Adapter Assembly  
Mount in the cab, no more than 12" from the foot throttle.

Pin	Description
1	Position Sensor #3
2	Position Sensor #1
3	Position Sensor #2
4	+5 Volt Reference
5	Signal Return
6	N/A

**Note:** For wiring on earlier engines contact FRC Engineering.

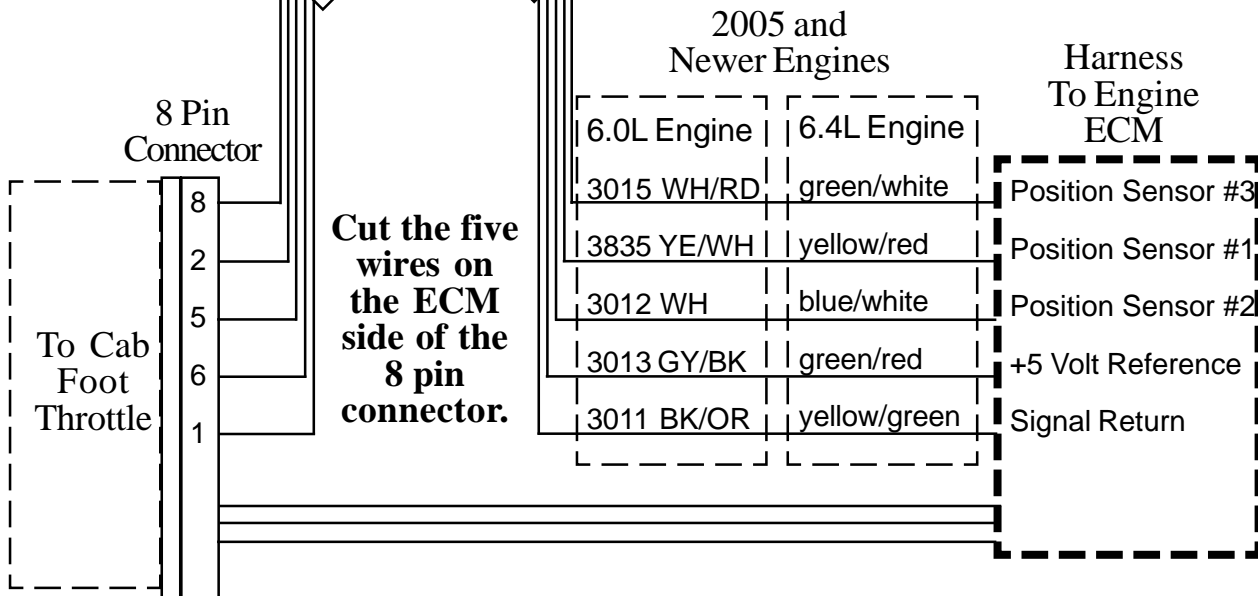

RPM Signal Levels	IDLE	MAX
Position Sensor #1	4.00V	0.60V
Position Sensor #2	1.42V	4.12V
Position Sensor #3	0.88V	3.53V

**Figure 15. Ford PRA206-B Wiring (Sheet 3 of 4)**

This page intentionally left blank.

# Mack PRA207 Cables

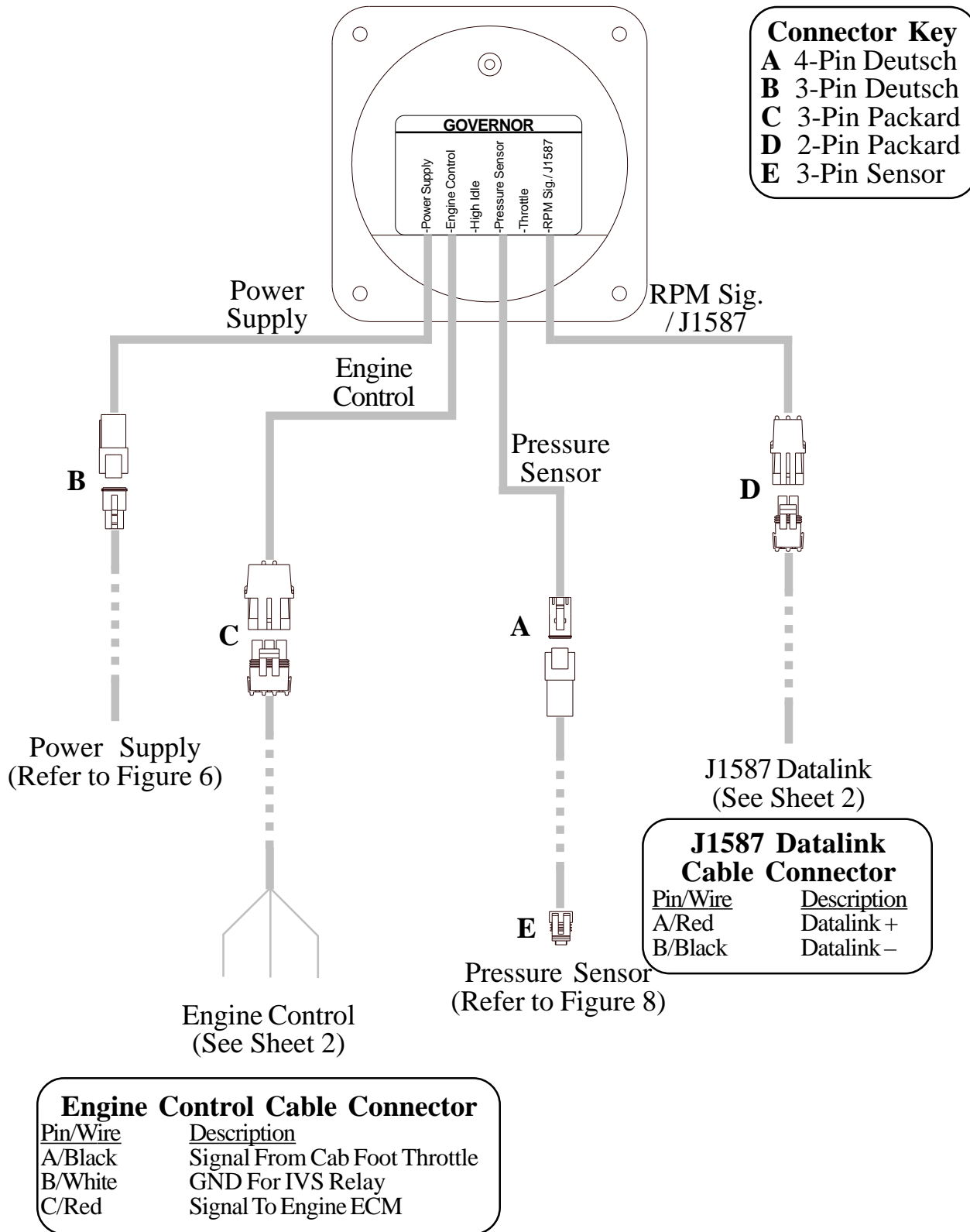

**Figure 16. Mack PRA207 Wiring (Sheet 1 of 2)**

# Mack Harness Connections

## Interface Information

The PRO-S Engine Control cable needs to be wired in series with the cab foot throttle. Use a voltmeter to determine which pin is Engine Control Signal.

Engine Control Signal will be 0.7 volts at idle and rise to approximately 3.8 volts as the foot pedal is pressed.

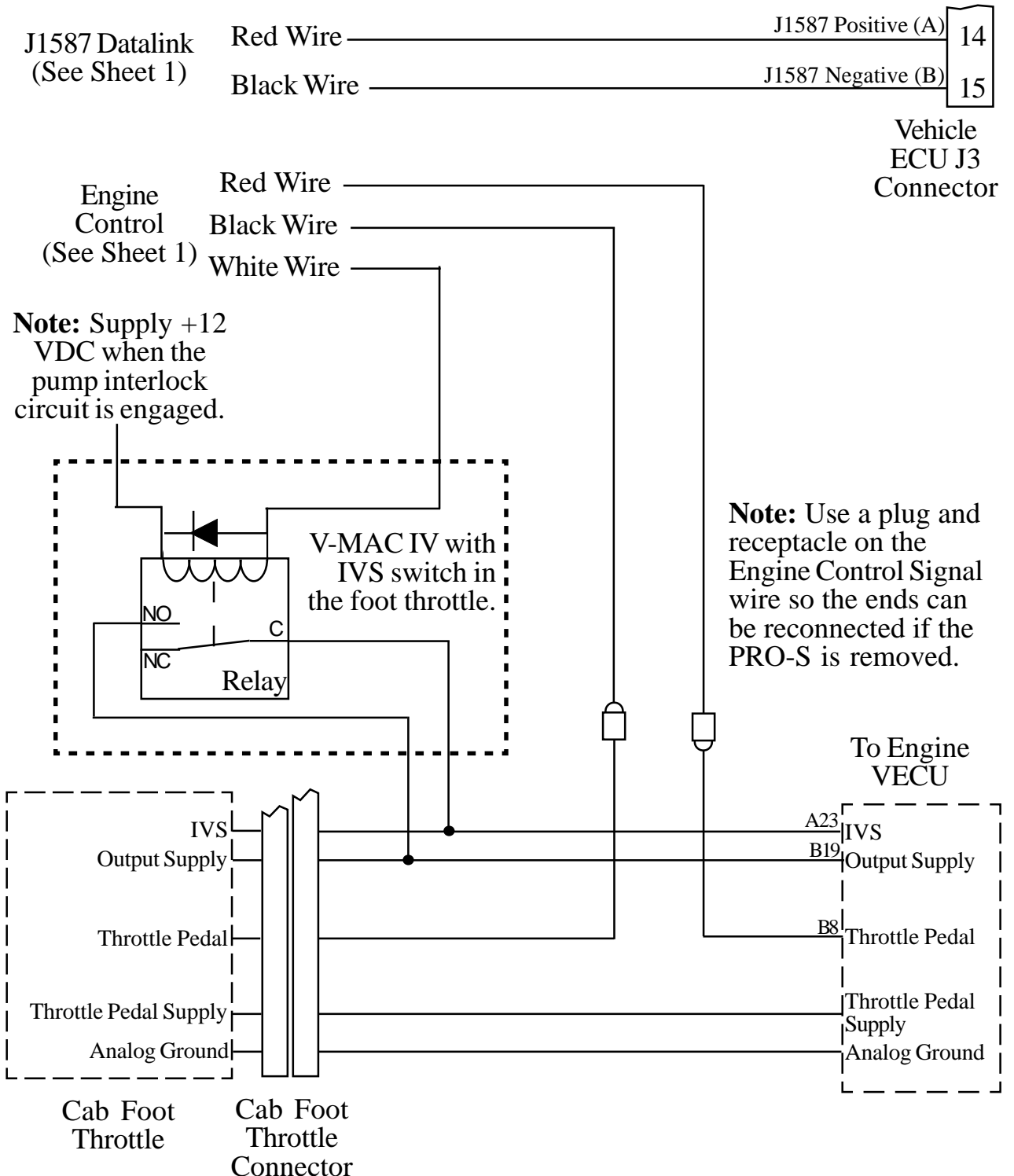

**Figure 16. Mack PRA207 Wiring  
(Sheet 2 of 2)**

# Scania PRA208-A Cables

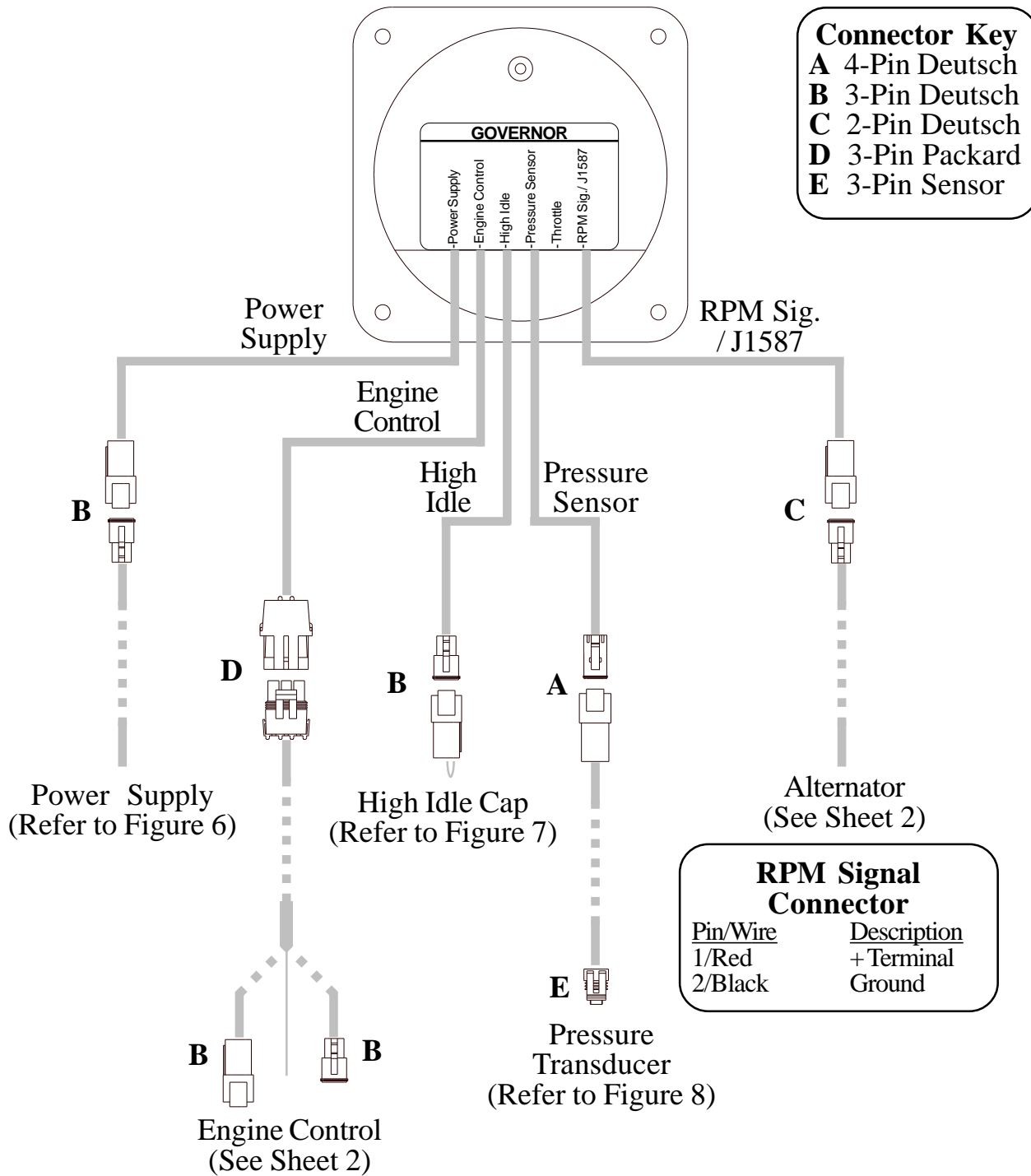
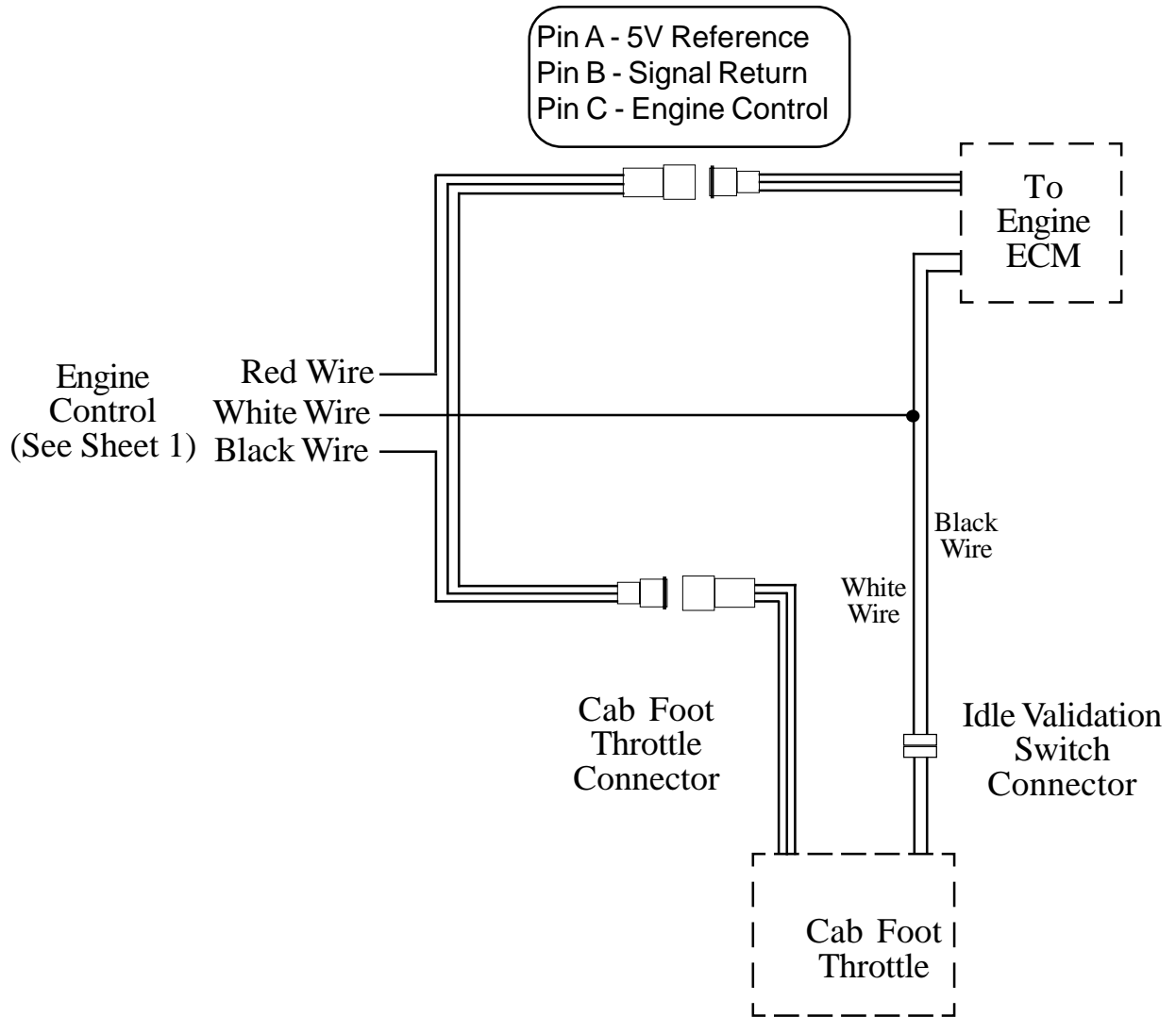

**Figure 17A. Scania PRA208-A Wiring (Sheet 1 of 2)**

# Scania Harness Connections

## Interface Information

Connect the alternator cable red wire to the small positive (+) terminal on the alternator and the black wire to chassis ground. Do not connect the wires to the large battery terminals.



**Figure 17A. Scania PRA208-A Wiring  
(Sheet 2 of 2)**

# Scania PRA208-B Cables

For use on P, R, and T-series trucks equipped with a bodywork control unit (BWS) (February 2005 and newer.)

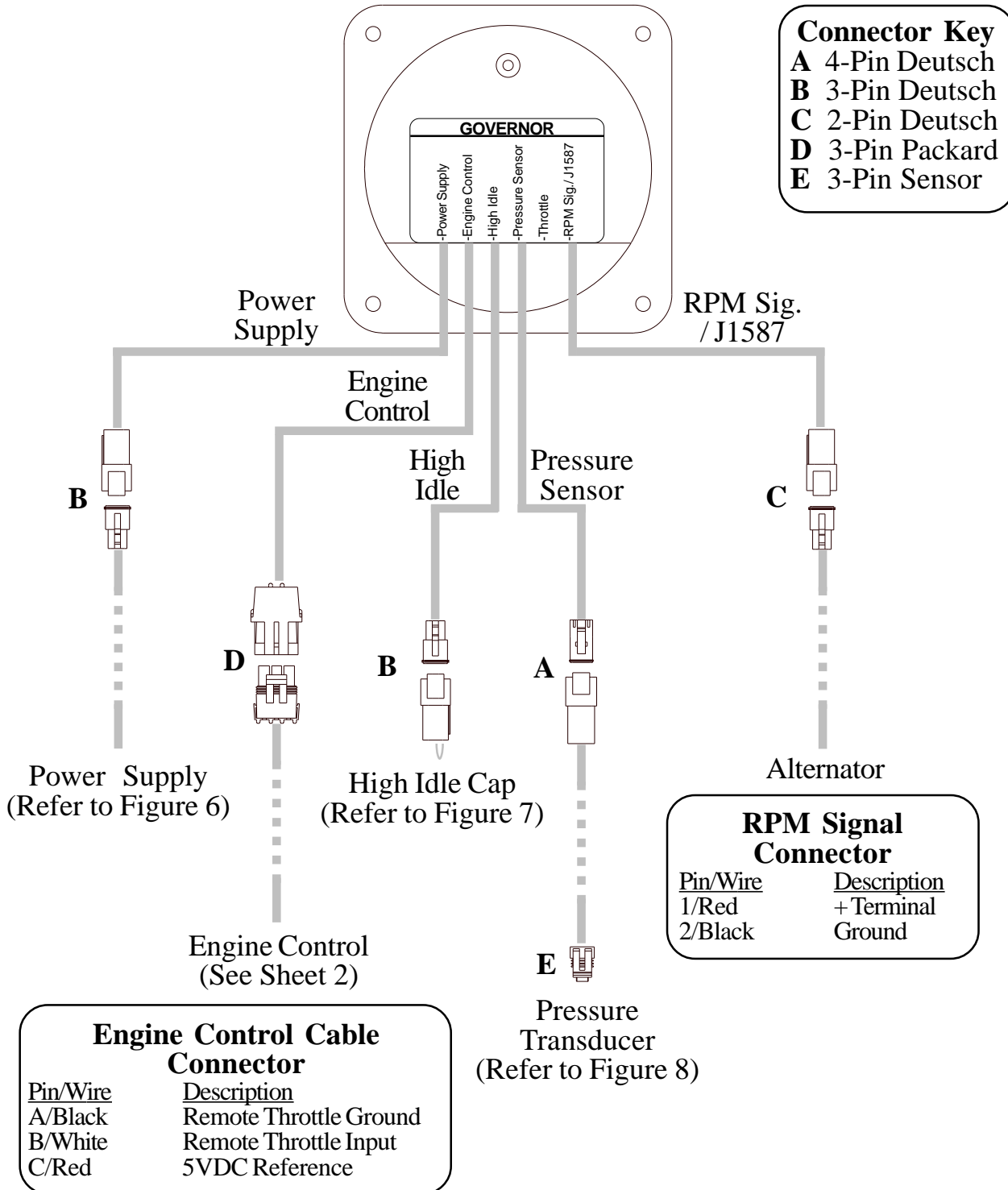
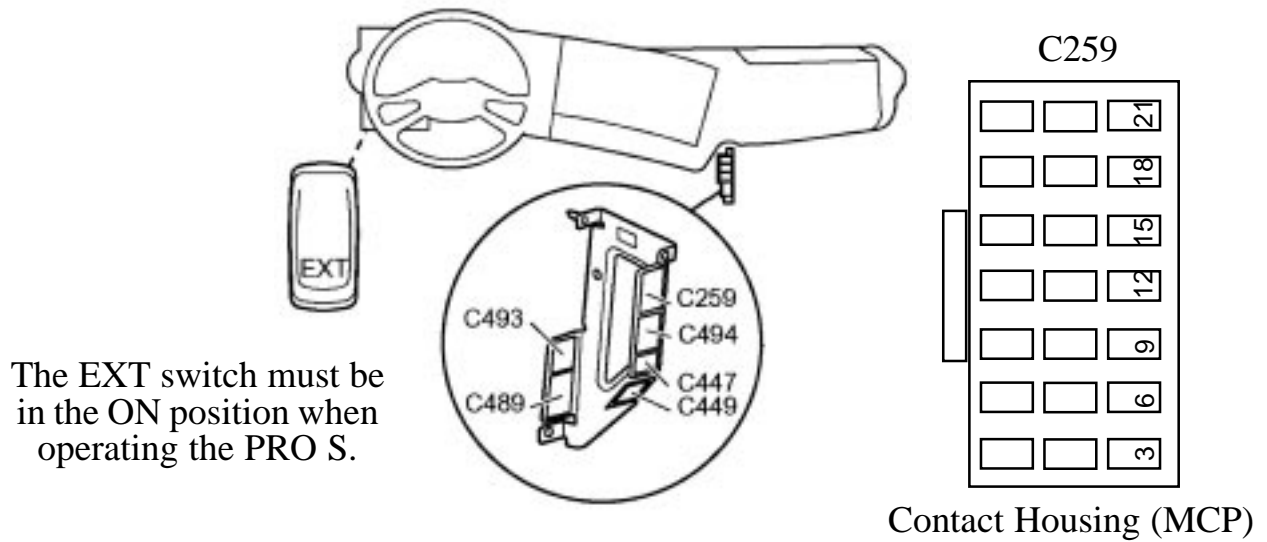

**Figure 17B. Scania PRA208-B Wiring (Sheet 1 of 2)**

# Scania Harness Connections

## Interface Information

Connector C259 is available on all vehicles ordered with any of the bodywork options. It is located on the plate for the electrical bodywork interface for body builders. Connector C259 is white and has 21 pins.



The EXT switch must be in the ON position when operating the PRO S.

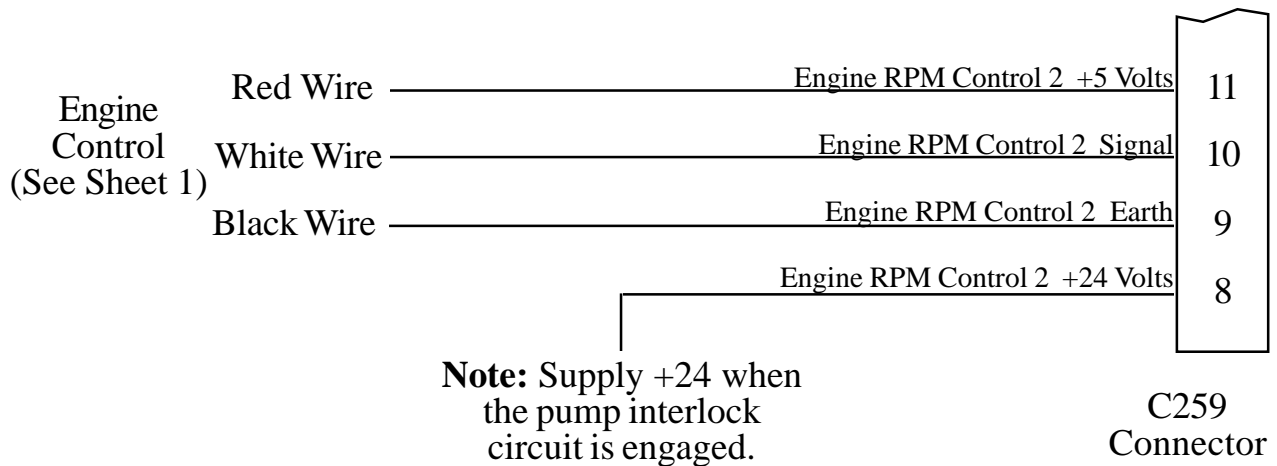

**Note:** Signal to pin10 is 0.6 to 3.0 V

**Figure 17B. Scania PRA208-B Wiring (Sheet 2 of 2)**

# Mercedes PRA210 Cables

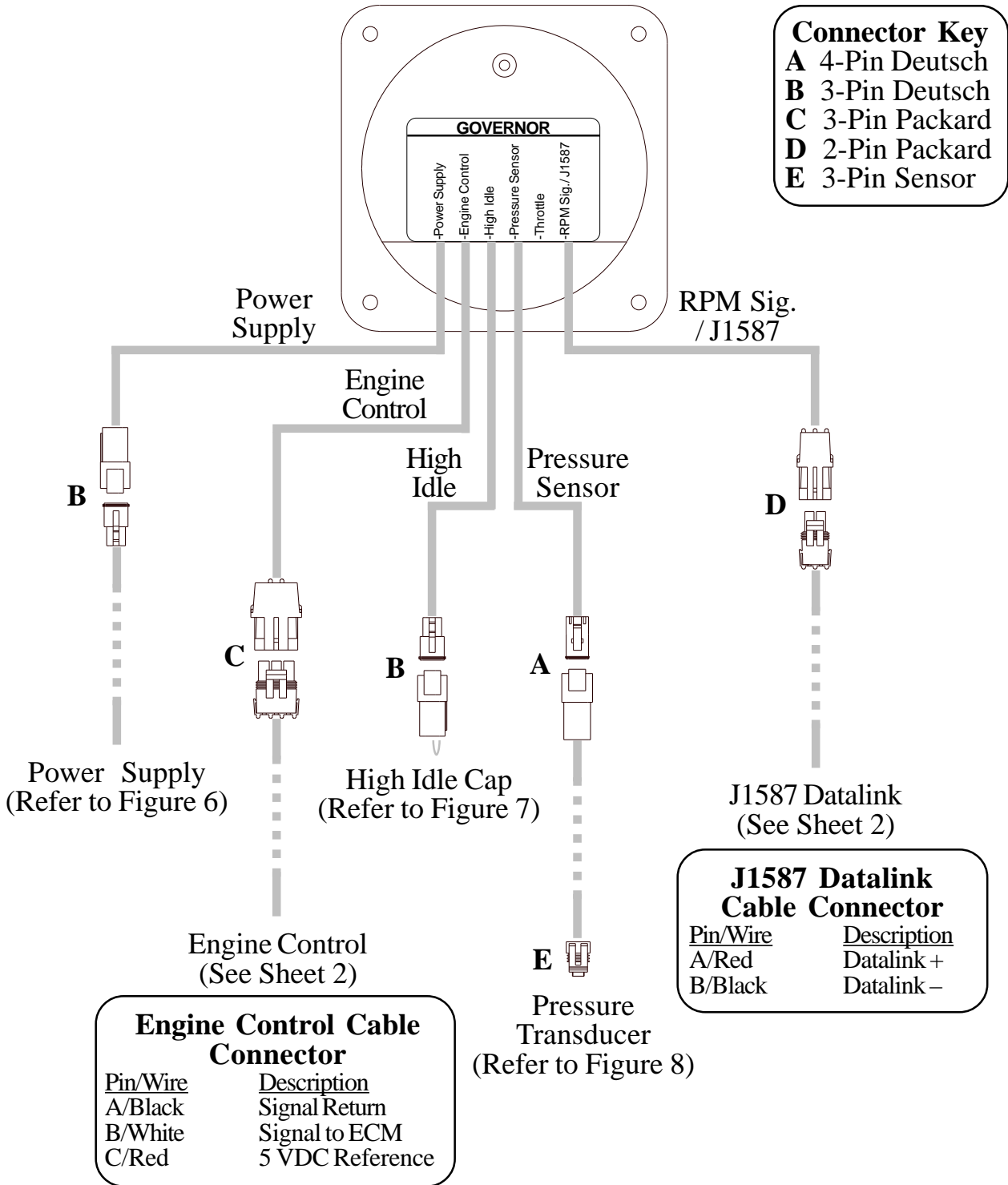
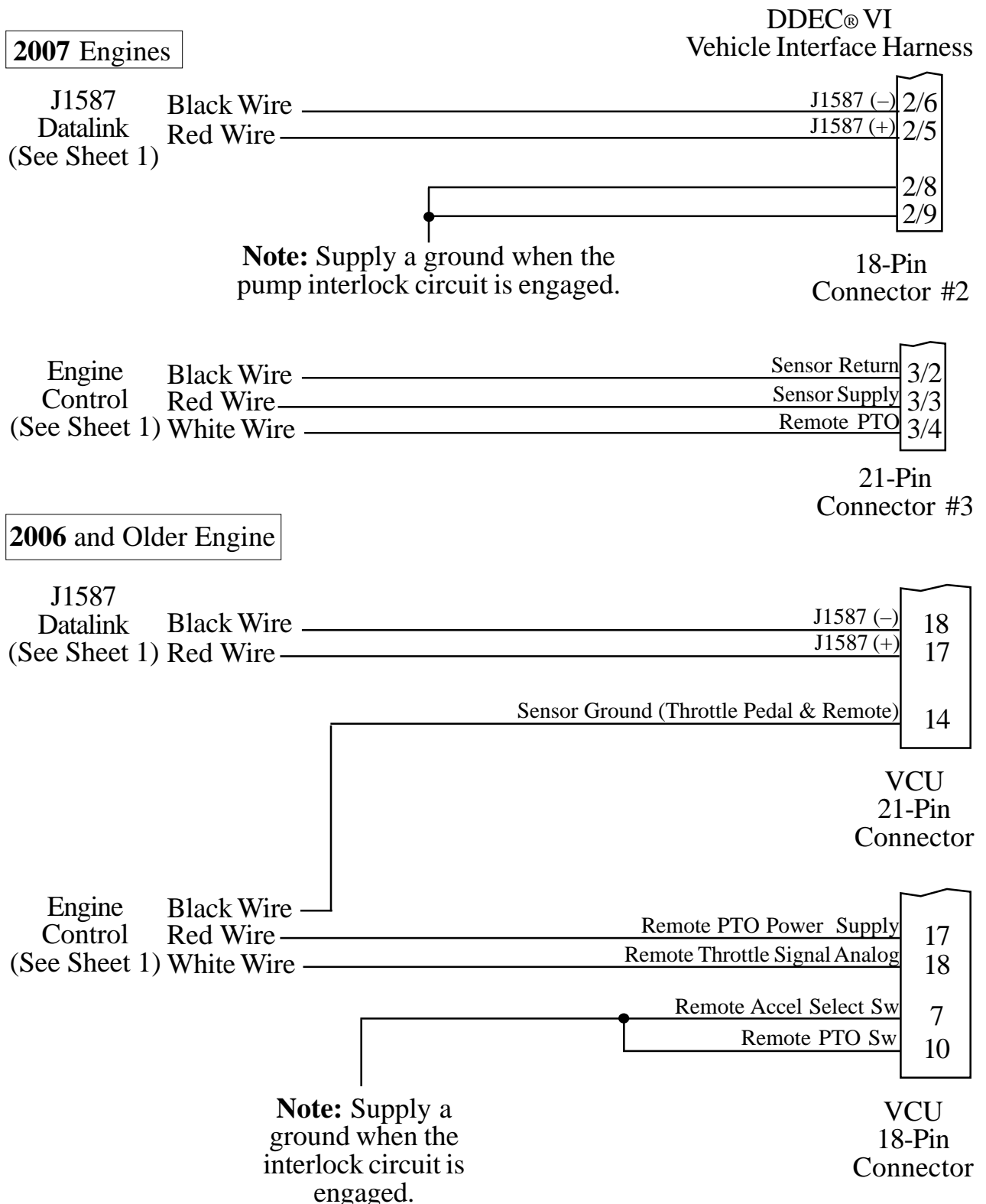

**Figure 18. Mercedes PRA210 Wiring (Sheet 1 of 2)**

# Mercedes Harness Connections

## Interface Information

Not available for Mercedes engine model year 2008 and newer.



**Figure 18. Mercedes PRA210 Wiring (Sheet 2 of 2)**

# FLYBACK DIODE INFORMATION

It is good engineering practice to include a flyback diode when switching an inductive load (solenoid coil, relay coil, electric motor winding, etc.). It is recommended that a flyback diode be installed on inductive devices that share a common power source/ground with a FRC governor.

Typical circuit showing a flyback diode installed across an inductive load.  
(Relay Coil, Solenoid, etc.)

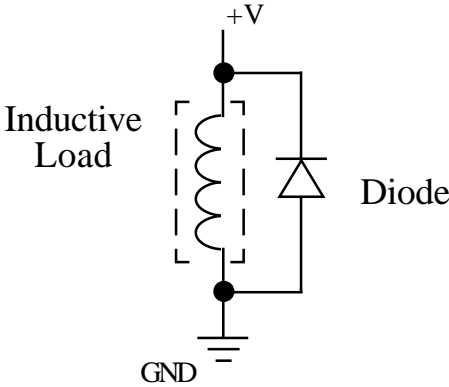
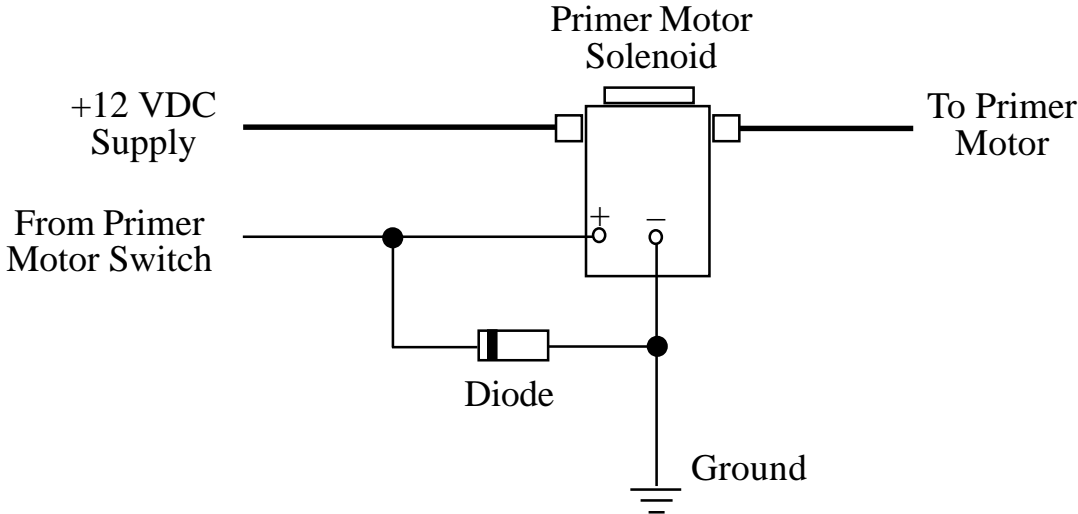

Diagram showing a flyback diode connected on a typical pump primer motor solenoid.



**Figure 19. Flyback Diode**